

Inline Cabinet Fan, Product # CSP-A200-QD, 70-254 CFM



Model CSP inline fans are high performance fans designed for exhaust, supply or return air applications where low sound level are required. Units feature an insulated, galvanized steel housing with a forward-curved wheel.

- 12.875 x 10 inch inlet width x height
- 8 x 8 inch outlet width x height
- Speed controllable, with up to 30% turndown

Certifications

AMCA Air
UL/cUL 507

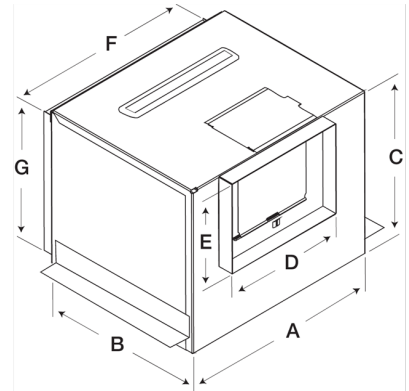

A	B	C	D	E	F	G
14 in	11.875 in	11.25 in	8 in	8 in	12.875 in	10 in

Performance Characteristics

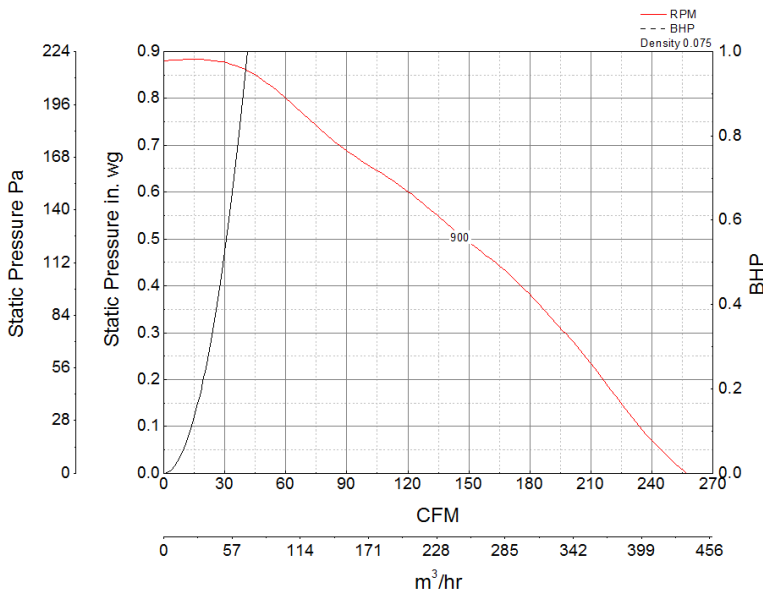

Construction Features

Housing Material	Galvanized Steel
Drive Type	Direct Drive
Impeller Type	Centrifugal Wheel
Impeller Material	Polypropylene
Includes	Access Panel Backdraft damper Mounting brackets
Certifications	AMCA Air UL/cUL 507
Speed Controllable	Yes

Motor Information

Motor Insulation	B
Motor Phase	1
Service Factor	1
Voltage	115
Hertz	60
Motor Enclosure	n/a
RPM	900
Thermal Protection	AutoOverload
Nominal Efficiency	29
Watts	16.4

Air and Sound Performance

Watts	Max Fan RPM	Min Fan RPM	Ps (in. wg)	0	0.125	0.25	0.375	0.5	0.625	0.75
58	900	720	CFM	254	226	203	178	145	109	70
			Sones	1	0.9	1.4	1.5	1.8	2.2	2.1



- Greenheck Fan Corporation certifies that the CSP models shown herein are licensed to bear the AMCA seal.
- The ratings shown are based on tests and procedures performed in accordance with AMCA Publication 211 and comply with the requirements of the AMCA Certified Ratings Program.
- The CSP models are not AMCA certified with 50 hertz motors.

California Residents

 **WARNING**

This product can expose you to chemicals including cadmium used in the processing of corrosion resistant metal and fasteners, which is known to the State of California to cause cancer and birth defects or other reproductive harm. For more information visit www.P65Warnings.ca.gov