

Submittal Data

Model BRC300 45° Cant Roof Curb

Standard Construction

- + 18 Gauge Galvanized Steel
- + 12" Height
- + Wood Nailer
- + Continuous Welds on Seams
- + 1" Thick, 3 lb. Rigid Fiberglass Insulation

Options

- + Aluminum Construction
- + Pressure-Treated Wood Nailer
- + 14, 16 Gauge Galvanized Construction
- + Different Flange Widths (Curb Size/Height)
- + Damper Tray

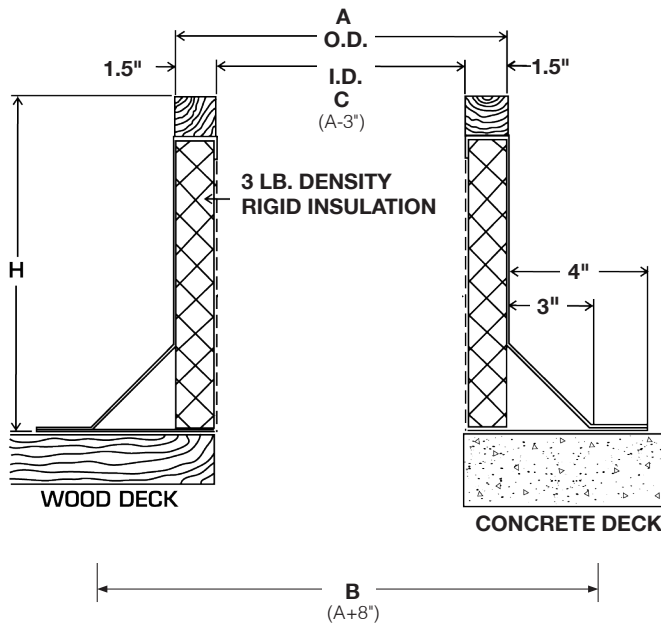
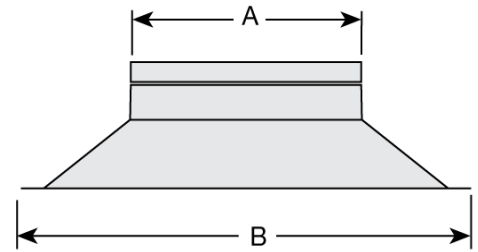
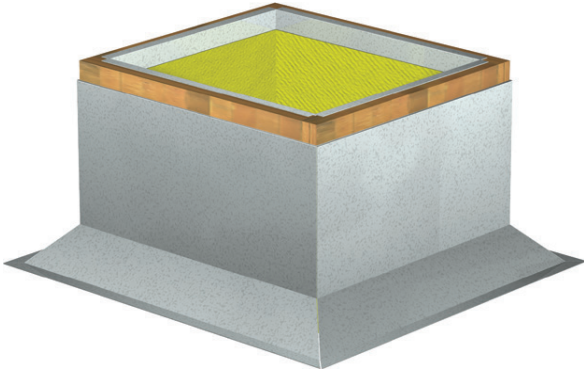

Dimensional Data

Size	A	B	C
17	16	24	13
19	18	26	15
22	21	29	18
30	29	37	26
34	33	41	30
40	39	47	36
46	45	53	42
52	51	59	48
58	57	65	54
64	63	71	60

All dimensions are in inches.

Buckley Associates, Inc.

Manufactured by Buckley Associates, Inc, Hanover, Massachusetts
Sheet Metal Union Local 17.

BCR200
January 2019

