

Roof Upblast/Sidewall Exhaust Size-200: CUBE • CUE • USGF

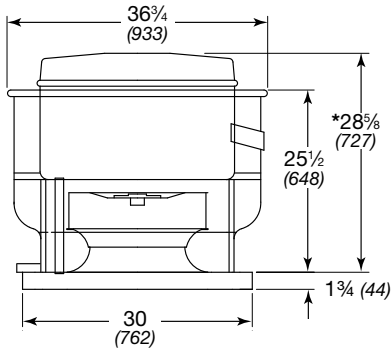

Direct Drive RPM

C-860 RPM
B-1140 RPM

All dimensions in inches (millimeters), weight in pounds (kilograms).
 * May be greater depending on motor.
 ^Weight shown is largest cataloged open drip-proof motor.

	CUBE	CUE	USGF
^Approximate Weight	142 (64)	170 (77)	213 (97)
Damper Size	18 x 18 (457 x 457)	N/A	N/A
Roof/Wall Opening	20 1/2 x 20 1/2 (521 x 521)		
Wall Opening with a Curb Through Wall	30 x 30 (762 x 762)	N/A	N/A

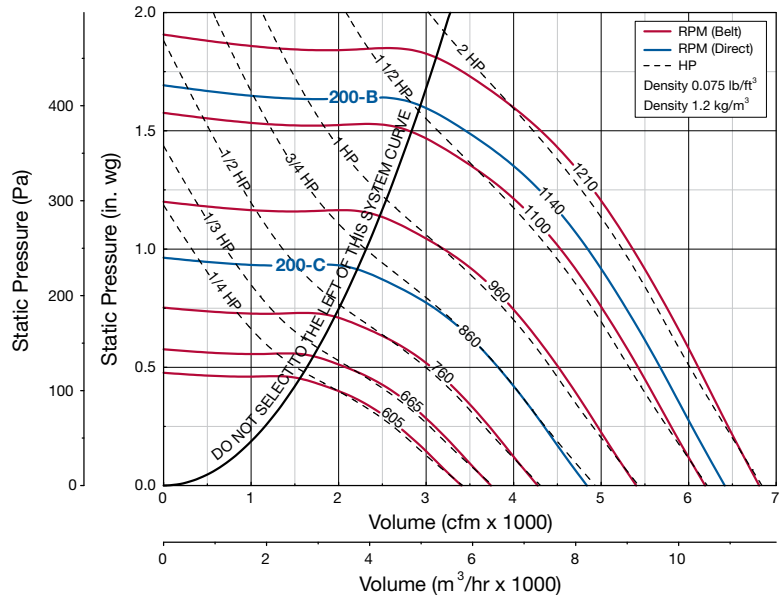

Motor HP	Fan RPM	Static Pressure in Inches wg	Static Pressure in Inches wg										
			0	0.125	0.25	0.375	0.5	0.75	1	1.25	1.5	1.75	
200													
1/4	605	CFM	3403	3054	2675	2144							
		BHP	0.25	0.26	0.26	0.25							
		Sones	8.2	7.6	6.8	6.2							
1/3	665	CFM	3740	3422	3096	2699	2073						
		BHP	0.33	0.34	0.35	0.35	0.33						
		Sones	9.6	9	8.3	7.5	7.2						
1/2	760	CFM	4275	3994	3718	3413	3048						
		BHP	0.49	0.51	0.52	0.52	0.51						
		Sones	12.3	11.8	11.1	10.2	9.5						
3/4	820	CFM	4612	4350	4098	3828	3523	2606					
		BHP	0.61	0.63	0.65	0.65	0.65	0.61					
		Sones	14.2	14.1	13.3	12.5	11.5	10.9					
	C-3/4	860	CFM	4837	4587	4346	4093	3815	3084				
			BHP	0.71	0.73	0.74	0.75	0.75	0.73				
			Sones	15.8	15.7	14.9	14.4	13	12				
875	CFM	4922	4676	4439	4192	3922	3240						
	BHP	0.75	0.77	0.78	0.79	0.79	0.78						
	Sones	16.4	16.4	15.6	15.1	13.7	12.6						
1	960	CFM	5400	5176	4958	4742	4508	3985	3169				
		BHP	0.98	1.01	1.03	1.04	1.04	1.04	1.00				
		Sones	18.9	18.6	18	17.4	16.7	15.2	14.7				
1 1/2	1030	CFM	5793	5585	5380	5179	4968	4503	3917	2972			
		BHP	1.22	1.24	1.26	1.28	1.29	1.29	1.27	1.18			
		Sones	21	21	20	19.7	19.2	17.8	16.6	17.1			
	1100	CFM	6187	5992	5798	5610	5421	5006	4529	3861			
		BHP	1.48	1.51	1.53	1.55	1.57	1.57	1.57	1.53			
		Sones	24	23	23	22	22	21	19.7	18.9			
2	B-2	1140	CFM	6412	6224	6036	5855	5674	5283	4837	4276	3445	
			BHP	1.65	1.67	1.7	1.72	1.74	1.74	1.74	1.73	1.63	
			Sones	25	24	24	23	22	22	21	19.6	20	
	1210	CFM	6806	6628	6451	6279	6108	5748	5350	4892	4289	3365	
		BHP	1.97	2	2.03	2.05	2.07	2.09	2.09	2.08	2.04	1.88	
		Sones	24	24	23	23	23	22	21	20	20	21	

MAXIMUM BHP AT A
 GIVEN RPM = (RPM/946)³
 MAXIMUM RPM = 1210
 TIP SPEED (ft/min) = RPM x 5.595
 MAXIMUM MOTOR FRAME SIZE = 184T
 AVERAGE DISCHARGE VELOCITY
 (FPM) = CFM/2.92

Performance certified is for installation type A: Free inlet, Free outlet. Power rating (Bhp) does not include transmission losses. Performance ratings do not include the effects of appurtenances (accessories). The sound ratings shown are loudness values in fan sones at 5 ft. (1.5 m) in a hemispherical free field calculated per AMCA Standard 301. Values shown are for installation type A: Free inlet hemispherical sone levels.