

BSQ 90 - Belt Drive

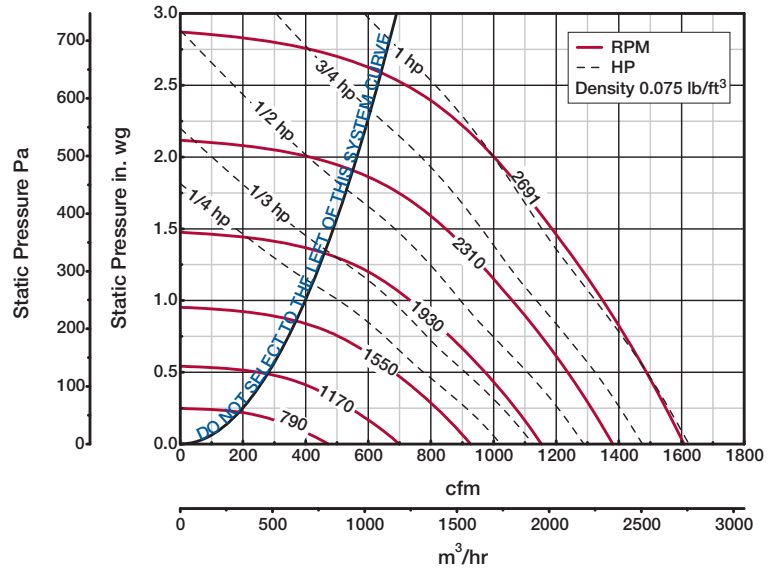
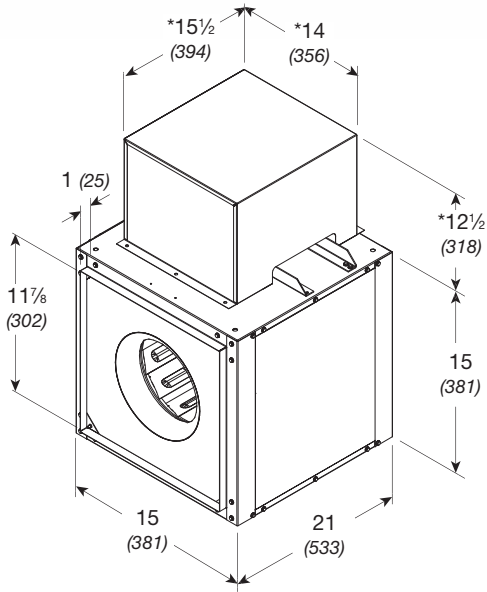

Damper size = 12 x 12 (305 x 305)
 Unit weight** = 84 (38)
 Housing thickness = 18 ga

Dimensions shown in inches (millimeters) and weight is shown in pounds (kilograms).
 *Motor cover is optional. Size may be greater depending on motor.
 **Weight shown is largest cataloged Open Drip Proof motor.

Model Number	Motor HP	Fan RPM	CFM / Static Pressure in Inches wg										
			0.125	0.250	0.500	0.750	1.000	1.500	1.750	2.000	2.250	2.500	
90													
90-4	1/4	1050	CFM	547	443								
			BHP	0.061	0.061								
			Sones	8.0	7.6								
		1211	CFM	655	574	333							
			BHP	0.092	0.095	0.084							
			Sones	9.8	9.1	8.3							
		1533	CFM	864	806	667	477						
			BHP	0.18	0.19	0.19	0.18						
			Sones	14.2	13.8	12.1	11.0						
		1694	CFM	965	914	798	654	437					
			BHP	0.25	0.25	0.26	0.25	0.22					
			Sones	16.0	15.8	14.4	13.1	12.3					
90-3	1/3	1780	CFM	1019	971	863	734	562					
			BHP	0.29	0.29	0.30	0.30	0.28					
			Sones	16.7	16.5	15.6	14.4	13.7					
		1866	CFM	1072	1028	926	808	657					
			BHP	0.33	0.33	0.35	0.35	0.33					
			Sones	17.5	17.3	16.9	15.9	15.4					
90-5	1/2	2136	CFM	1239	1202	1118	1024	917	638				
			BHP	0.49	0.50	0.51	0.52	0.52	0.47				
			Sones	21	21	21	19.9	19.2	18.4				
90-7	3/4	2291	CFM	1334	1300	1223	1138	1045	811	668			
			BHP	0.61	0.61	0.62	0.64	0.65	0.61	0.58			
			Sones	23	23	22	22	21	20	20			
		2445	CFM	1429	1396	1326	1249	1167	976	844	707		
			BHP	0.73	0.74	0.75	0.77	0.79	0.77	0.73	0.70		
			Sones	25	25	24	25	23	22	22	23		
90-10	1	2568	CFM	1504	1473	1407	1336	1258	1082	977	851	704	
			BHP	0.85	0.86	0.87	0.89	0.90	0.90	0.88	0.84	0.80	
			Sones	26	26	26	26	26	24	22	24	25	
		2691	CFM	1579	1549	1488	1420	1347	1186	1097	987	866	713
			BHP	0.98	0.98	1.00	1.02	1.03	1.05	1.03	1.00	0.96	0.91
			Sones	28	28	27	28	28	26	25	24	26	29

MAX Bhp AT A GIVEN RPM = (rpm/2691)³
 MAXIMUM RPM = 2691
 TIP SPEED (ft/min) = rpm x 2.928
 MAX NEMA MOTOR FRAME SIZE = 145T
 OUTLET VELOCITY (ft/min) = 1.0212 x cfm

Performance certified is for installation type B: Free inlet, Ducted outlet. Power rating (Bhp) does not include transmission losses. Performance ratings do not include the effects of appurtenances (accessories).

The sound ratings shown are loudness values in fan sones at 1.5 m (5 feet) in a hemispherical free field calculated per AMCA International Standard 301. Values shown are for installation type B: free inlet hemispherical sone levels.