

BSQ 80 - Belt Drive

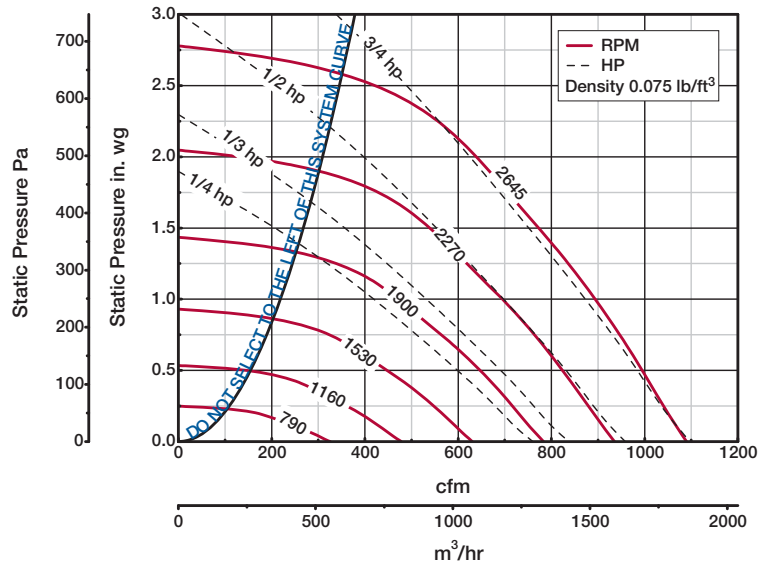
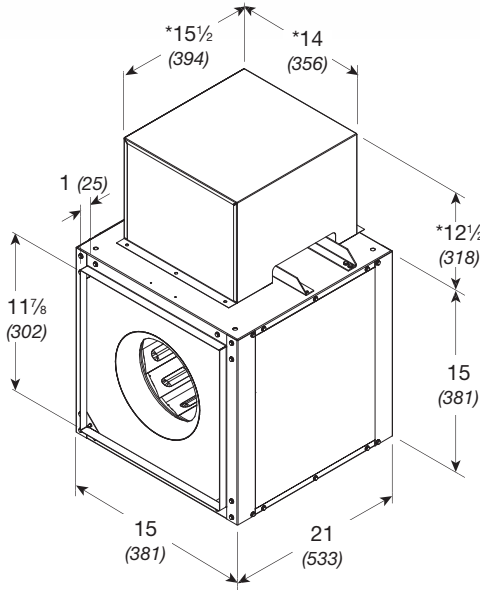

Damper size = 12 x 12 (305 x 305)
 Unit weight** = 79 (36)
 Housing thickness = 18 ga

Dimensions shown in inches (millimeters) and weight is shown in pounds (kilograms).
 *Motor cover is optional. Size may be greater depending on motor.
 **Weight shown is largest cataloged Open Drip Proof motor.

Model Number	Motor HP	Fan RPM	CFM / Static Pressure in Inches wg										
			0.125	0.250	0.500	0.750	1.000	1.250	1.500	1.750	2.000	2.500	
80													
80-4	1/4	1050	CFM	372	298								
			BHP	0.049	0.049								
			Sones	8.0	7.6								
		1207	CFM	445	386	206							
			BHP	0.073	0.075	0.065							
			Sones	9.7	9.1	8.2							
	1520	CFM	585	542	442	301							
		BHP	0.15	0.15	0.15	0.14							
		Sones	13.9	13.5	11.8	10.8							
	1676	CFM	652	615	530	426	254						
		BHP	0.19	0.20	0.20	0.20	0.17						
		Sones	15.9	15.6	14.1	12.9	11.5						
1833	CFM	720	687	613	524	424							
	BHP	0.25	0.26	0.26	0.26	0.25							
	Sones	17.2	16.9	16.3	15.3	14.3							
80-3	1/3	1926	CFM	760	728	660	579	486	346				
			BHP	0.29	0.30	0.30	0.30	0.30	0.27				
			Sones	18.4	18.3	17.8	17.1	16.9	13.9				
		2018	CFM	799	769	704	630	545	452	269			
			BHP	0.34	0.34	0.35	0.35	0.34	0.34	0.28			
			Sones	19.6	19.5	19.2	18.4	18.1	16.7	13.5			
80-5	1/2	2164	CFM	861	833	774	708	633	550	442			
			BHP	0.41	0.42	0.43	0.43	0.43	0.42	0.40			
			Sones	21	21	21	20	19.6	19.2	17.6			
		2310	CFM	924	897	842	784	716	643	563	445		
			BHP	0.50	0.51	0.52	0.52	0.52	0.52	0.51	0.48		
			Sones	23	23	22	23	21	21	20	19.9		
80-7	3/4	2478	CFM	995	969	919	865	807	743	671	597	486	
			BHP	0.62	0.63	0.63	0.64	0.65	0.65	0.64	0.63	0.59	
			Sones	25	25	24	25	24	23	22	22	23	
		2645	CFM	1065	1041	995	945	894	835	773	705	635	395
			BHP	0.75	0.76	0.77	0.78	0.79	0.79	0.78	0.77	0.77	0.65
			Sones	28	28	27	27	27	26	25	24	24	35

MAX Bhp AT A GIVEN RPM = (rpm/2866)³
 MAXIMUM RPM = 2645
 TIP SPEED (ft/min) = rpm x 2.928
 MAX NEMA MOTOR FRAME SIZE = 145T
 OUTLET VELOCITY (ft/min) = 1.0212 x cfm

Performance certified is for installation type B: Free inlet, Ducted outlet. Power rating (Bhp) does not include transmission losses. Performance ratings do not include the effects of appurtenances (accessories).
 The sound ratings shown are loudness values in fan sones at 1.5 m (5 feet) in a hemispherical free field calculated per AMCA International Standard 301. Values shown are for installation type B: free inlet hemispherical sone levels.