

BSQ 180 - Belt Drive

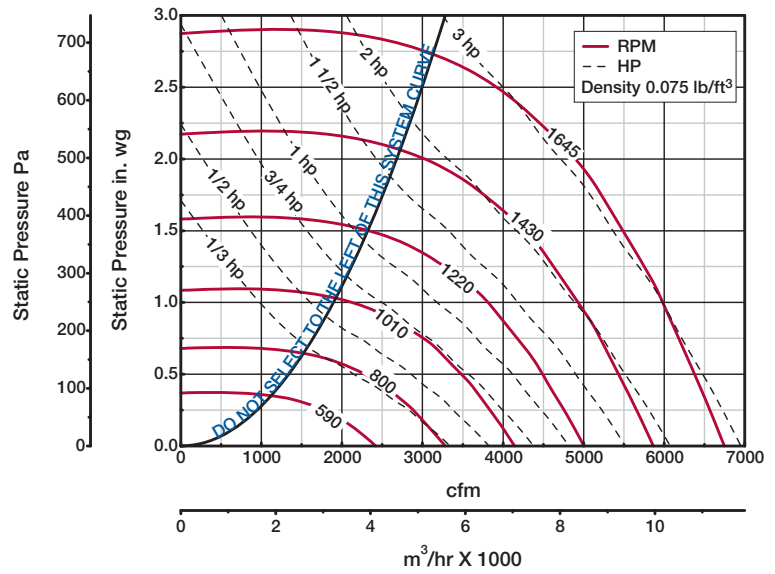
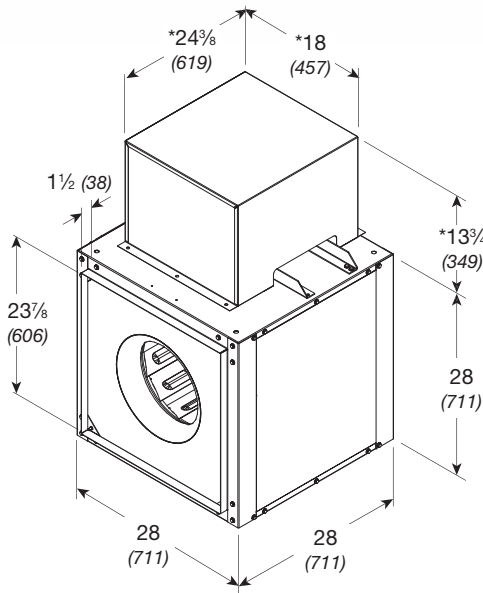

Damper size = 24 x 24 (610 x 610)
 Unit weight** = 245 (111)
 Housing thickness = 18 ga

Dimensions shown in inches (millimeters) and weight is shown in pounds (kilograms).
 *Motor cover is optional. Size may be greater depending on motor.
 **Weight shown is largest cataloged Open Drip Proof motor.

Model Number	Motor HP	Fan RPM	CFM / Static Pressure in Inches wg										
			0.125	0.250	0.500	0.750	1.000	1.250	1.500	1.750	2.000	2.500	
180													
180-3	1/3	700	CFM	2649	2387								
			BHP	0.23	0.24								
			Sones	10.0	9.6								
		791	CFM	3051	2845	2217							
			BHP	0.32	0.34	0.35							
			Sones	10.6	10.9	9.6							
180-5	1/2	905	CFM	3546	3366	2928	2175						
			BHP	0.48	0.49	0.52	0.49						
			Sones	12.2	12.1	11.6	10.8						
180-7	3/4	1037	CFM	4109	3955	3616	3179	2432					
			BHP	0.71	0.73	0.77	0.79	0.73					
			Sones	14.5	14.2	13.5	13.4	12.8					
180-10	1	1141	CFM	4549	4412	4127	3760	3290	2523				
			BHP	0.94	0.96	1.01	1.04	1.04	0.96				
			Sones	16.5	16.1	15.4	15.0	14.9	13.8				
180-15	1 1/2	1224	CFM	4898	4774	4507	4194	3836	3300	2331			
			BHP	1.15	1.18	1.23	1.28	1.29	1.27	1.08			
			Sones	18.4	17.7	17.1	16.5	16.5	15.8	14.4			
		1306	CFM	5242	5128	4878	4610	4281	3884	3332			
			BHP	1.40	1.43	1.48	1.53	1.56	1.57	1.50			
			Sones	20	19.5	18.8	18.3	17.8	17.5	16.8			
180-20	2	1372	CFM	5519	5410	5174	4937	4630	4308	3854	3218		
			BHP	1.62	1.65	1.71	1.75	1.81	1.82	1.81	1.7		
			Sones	22	21	20	19.8	19.0	18.7	18.3	17.5		
		1437	CFM	5790	5686	5463	5236	4964	4662	4298	3814	3106	
			BHP	1.86	1.89	1.95	2.00	2.06	2.09	2.09	2.04	1.89	
			Sones	23	22	22	21	21	19.7	19.6	19.1	18.2	
180-30	3	1541	CFM	6224	6127	5922	5710	5488	5213	4927	4567	4116	
			BHP	2.29	2.32	2.38	2.45	2.50	2.56	2.58	2.57	2.52	
			Sones	26	25	25	24	24	22	22	21	21	
		1645	CFM	6656	6566	6377	6179	5981	5744	5485	5216	4866	3898
			BHP	2.78	2.81	2.88	2.95	3.01	3.07	3.12	3.14	3.13	2.94
			Sones	29	28	28	27	27	26	24	24	24	23

MAX Bhp at A GIVEN RPM = (rpm/1125)³
 MAXIMUM RPM = 1645
 TIP SPEED (ft/min) = rpm x 4.843
 MAX NEMA MOTOR FRAME SIZE = 184T
 OUTLET VELOCITY (ft/min) = 0.2553 x cfm

Performance certified is for installation type B: Free inlet, Ducted outlet. Power rating (Bhp) does not include transmission losses. Performance ratings do not include the effects of appurtenances (accessories).
 The sound ratings shown are loudness values in fan sones at 1.5 m (5 feet) in a hemispherical free field calculated per AMCA International Standard 301. Values shown are for installation type B: free inlet hemispherical sone levels.