

BSQ 140 - Belt Drive

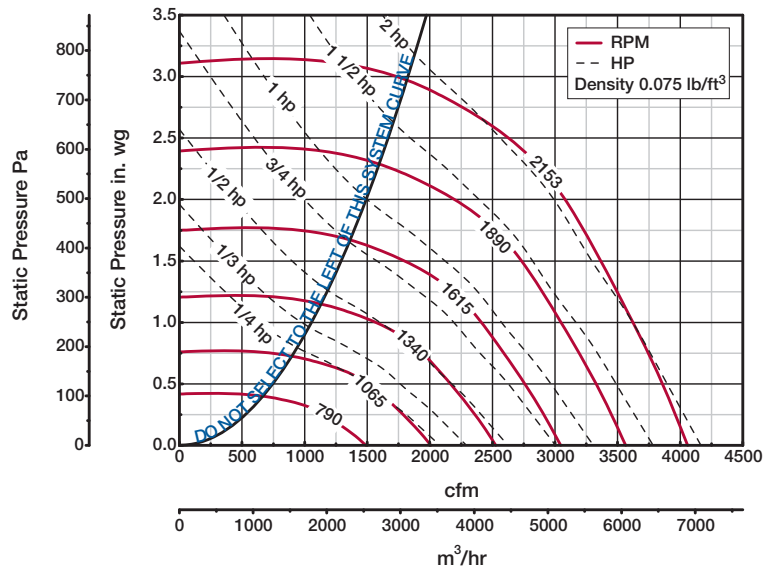
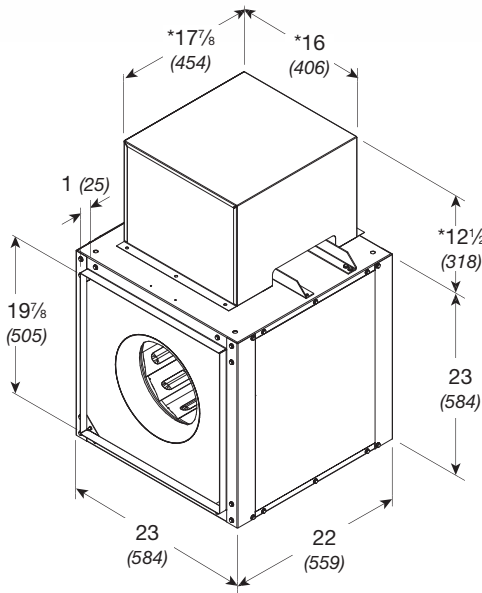

Damper size = 20 x 20 (508 x 508)
 Unit weight** = 111 (50)
 Housing thickness = 18 ga

Dimensions shown in inches (millimeters) and weight is shown in pounds (kilograms).
 *Motor cover is optional. Size may be greater depending on motor.
 **Weight shown is largest cataloged Open Drip Proof motor.

Model Number	Motor HP	Fan RPM	CFM / Static Pressure in Inches wg										
			0.125	0.250	0.500	0.750	1.000	1.500	1.750	2.000	2.500	2.750	
140													
140-4	1/4	800	CFM	1362	1185								
			BHP	0.10	0.11								
			Sones	6.3	6.7								
		1076	CFM	1927	1810	1538							
			BHP	0.24	0.25	0.26							
			Sones	10.7	10.7	10.2							
140-3	1/3	1185	CFM	2142	2039	1807	1463						
			BHP	0.32	0.33	0.35	0.34						
			Sones	12.1	11.9	12.0	10.6						
140-5	1/2	1271	CFM	2311	2217	2006	1741	1199					
			BHP	0.39	0.41	0.43	0.43	0.39					
			Sones	13.3	13.0	13.1	13.0	12.7					
		1356	CFM	2476	2392	2197	1979	1636					
			BHP	0.48	0.49	0.51	0.52	0.51					
			Sones	14.2	13.9	13.8	13.8	13.8					
140-7	3/4	1553	CFM	2858	2787	2626	2449	2253	1447				
			BHP	0.71	0.73	0.75	0.78	0.79	0.70				
			Sones	16.2	16.0	16.0	15.6	15.3	13.9				
140-10	1	1631	CFM	3008	2941	2790	2625	2446	1865				
			BHP	0.82	0.84	0.86	0.89	0.91	0.87				
			Sones	17.1	16.9	16.9	16.6	16.1	14.8				
		1709	CFM	3159	3094	2953	2798	2635	2177	1752			
			BHP	0.95	0.96	0.99	1.02	1.05	1.03	0.97			
			Sones	18.2	18.0	17.9	17.7	17.2	16.1	15.1			
140-15	1 1/2	1956	CFM	3633	3576	3461	3330	3193	2894	2705	2457		
			BHP	1.41	1.43	1.47	1.49	1.53	1.57	1.57	1.55		
			Sones	24	23	24	24	23	22	21	20		
140-20	2	2055	CFM	3822	3769	3662	3537	3410	3136	2982	2777	2168	
			BHP	1.63	1.66	1.70	1.73	1.75	1.82	1.82	1.81	1.70	
			Sones	27	26	28	27	26	25	24	23	21	
		2153	CFM	4009	3958	3856	3741	3622	3365	3225	3078	2627	2260
			BHP	1.88	1.90	1.95	1.98	2.00	2.08	2.10	2.10	2.05	1.95
			Sones	30	30	31	31	30	28	28	27	25	23

MAX Bhp AT A GIVEN RPM = (rpm/1682)³
 MAXIMUM RPM = 2153
 TIP SPEED (ft/min) = rpm x 3.812
 MAX NEMA MOTOR FRAME SIZE = 145T
 OUTLET VELOCITY (ft/min) = 0.3692 x cfm

Performance certified is for installation type B: Free inlet, Ducted outlet. Power rating (Bhp) does not include transmission losses. Performance ratings do not include the effects of appurtenances (accessories).
 The sound ratings shown are loudness values in fan sones at 1.5 m (5 feet) in a hemispherical free field calculated per AMCA International Standard 301. Values shown are for installation type B: free inlet hemispherical sone levels.