

Submittal Data

Model 150A Buckley 1.5 HR Rated Static Fire Damper

Application

Model 150A is a static rated fire damper approved for use in walls and partitions with fire resistance ratings less than 3 hours. This model carries a 1½" hour UL fire damper label. UL555 classifies static rated fire dampers for use in HVAC systems that are automatically shut down in the event of a fire.

Standard Construction

- + 22 Gauge Galvanized Steel Blades and Frame
- + Blades Completely In Air Stream
- + 165° F Fusible Link (replaceable)
- + Horizontal or Vertical Mount Available
- + UL555 Fire Resistant Rating 1.5 Hours Listing R13317

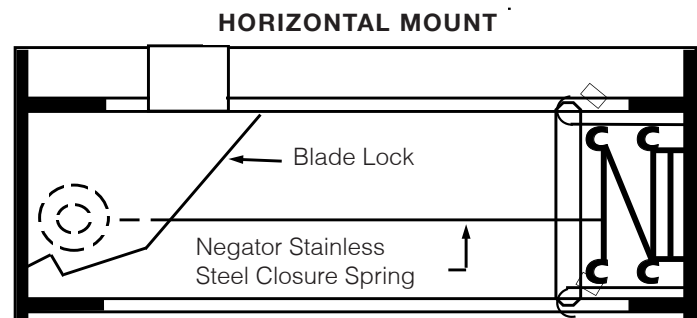
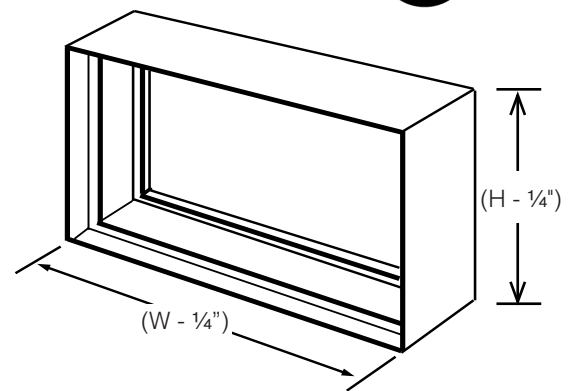
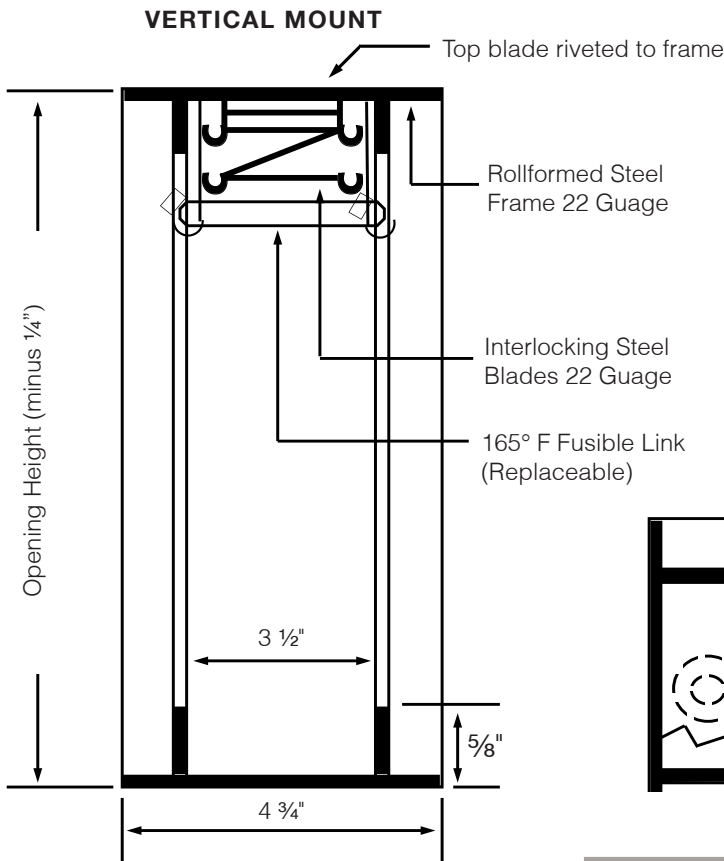

Underwriters laboratories classifies for use in 2 hour fire partitions.

For multiple assembly sizes consult U.L. Listing Card or U.L. Fire Resistance Index.

	Single Section Size Availability			
	Vertical		Horizontal	
	Width × Height		Width × Height	
Minimum Section	4"	4"	4"	4"
Maximum Section	60"	60"	48"	48"

Buckley Associates, Inc.

Manufactured by Buckley Associates, Inc, Hanover, Massachusetts
Sheet Metal Union Local 17.

150A
May 2019

