

630-1-2 Alum Return Grille, 45deg Blades, 3/4" Spacing

Core Style:

Single Deflection

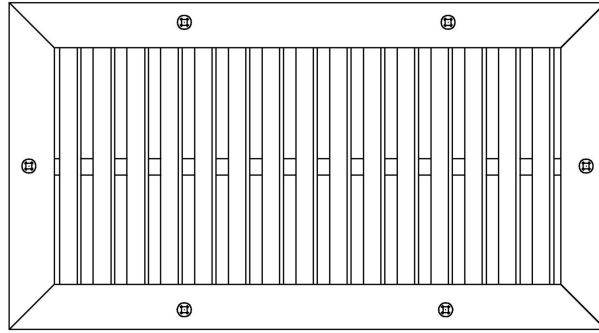
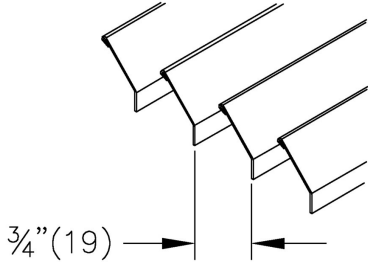

Fastening:

A: Countersunk Screwholes c/w Screws

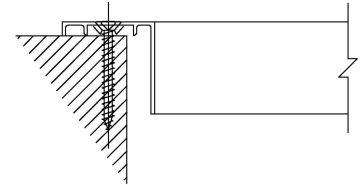

Border: F 1 1/4" (32) Flat Frame Standard

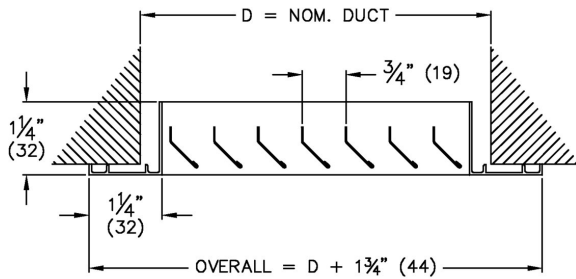

Material:

- Aluminum

Finish:

- B12 - Standard White

Damper: VCS3 Coated Steel Opposed Blade Damper (Mill Finish)

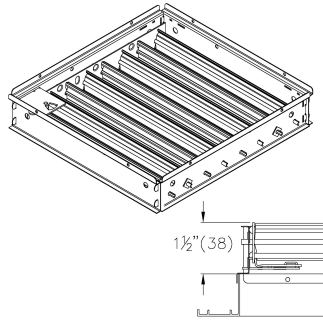

Notes:

- Blades parallel to Short dimension
- 45° Deflection roll formed blades on 3/4" (19) centers
- VCS3 opposed blade damper, coated steel
- Factory tolerance $\pm 1/32"$ (1)
- Mullions are included when blades are parallel to nominal size dimension larger than 8" (203).

PROJECT: price odd stock
ENGINEER:
DESCRIPTION: Alum Return Grille, 45deg Blades, 3/4" Spacing
630-1-2//I/36.000/10.000/SM/F///S/A//VCS3/B12

SUBMITTAL NO: 269136
CUSTOMER:

SUBMITTAL DATE: 9/16/2020