

Submittal Data

Model PELV-100 Penthouse Elevator Vented Hood

Application and Design

The PELV-100 Penthouse Elevator Vented Hood is a gravity ventilator penthouse with an 18" x 18" gasketed access door and a low leakage opposed blade control damper with either a 24VAC or 120 volt actuator. The unit is provided with weather hood(s) to help minimize wind driven rain and snow infiltration. The unit is shop assembled and shipped loose from the curb.

Standard Construction

- Finish** Mill
- Roof** 18 ga. galvanized with 0.5 in. insulation
- Hood** 18 ga. galvanized, non-insulated with 3/4" x 3/4" Stamped Grille in Opening
- Curb** 18 ga. galvanized, 2 in. mounting flange, welded construction, 1" thick insulation

Model.....Buckley GPI
Size See Chart

Damper

ModelGreenheck VCD-23
Size and Free Area..... See Chart
Actuator..... 120V or 24VAC, Mounted Internally with End Switch, Power Closed, Fail Open

Options

- Glass** 0.125 in. clear tempered glass
- Aluminum Construction** Roof (.090) and Hood (.063)

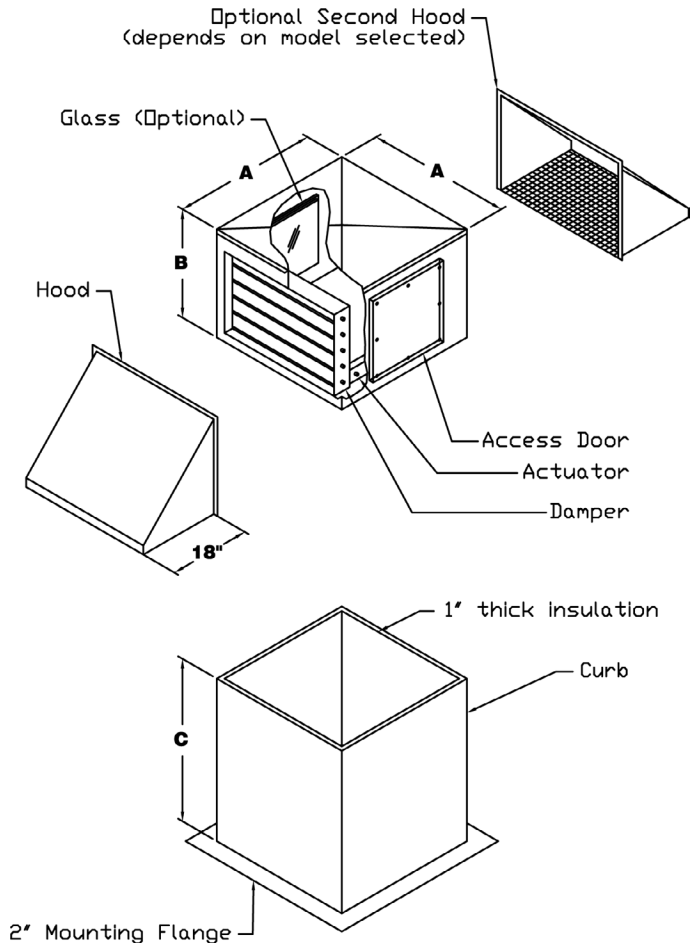

	Model	Dimensional Data			Curb	Optional Glass	Damper			Hood		
		A	B	C	Size (O.D.)	Size (O.D.)	Qty	Size	Actuator	Qty	Opening Size	Total Free Area*
<input type="checkbox"/>	PELV-100-32-1	32	24¾	36	31½ x 31½	18 x 14	1	26 x 18	TFB24-S TFB120-S	1	30 x 18	3.0 sq. ft.
<input type="checkbox"/>	PELV-100-32-2	32	24¾	36	31½ x 31½	18 x 14	2	26 x 18	TFB24-S TFB120-S	2	30 x 18	6.0 sq. ft.
<input type="checkbox"/>	PELV-100-38-1	38	24¾	36	37½ x 37½	24 x 14	1	32 x 18	TFB24-S TFB120-S	1	36 x 18	3.6 sq. ft.
<input type="checkbox"/>	PELV-100-38-2	38	24¾	36	37½ x 37½	24 x 14	2	32 x 18	TFB24-S TFB120-S	2	36 x 18	7.2 sq. ft.
<input type="checkbox"/>	PELV-100-44-1	44	24¾	36	43½ x 43½	30 x 14	1	38 x 18	FSNF24-S FSNF120-S	1	42 x 18	4.2 sq. ft.
<input type="checkbox"/>	PELV-100-44-2	44	24¾	36	43½ x 43½	30 x 14	2	38 x 18	FSNF24-S FSNF120-S	2	42 x 18	8.4 sq. ft.

Unless otherwise noted, all dimensions are in inches.

*The Total Free Area is based on the assumption that 80% of the screen is open.

Water Infiltration Disclosure

Louvered penthouses provide a level of defense against weather infiltration, however; louvered penthouses cannot be considered weather proof. Buckley recommends provisions to manage weather infiltration be present beyond the louvered penthouse so as to mitigate weather passage and prevent weather related damage to building conditions or equipment. Design of or materials as required to manage weather infiltration are not provided by Buckley. Buckley also recommends sound product application/engineering practice(s) be employed when applying louvered penthouses. Such practice(s) may include, but are not limited to, conservative throat and louver face area velocities. Buckley shall not be held liable for water related damage to building conditions or equipment.

Buckley Associates, Inc.

Manufactured by Buckley Associates, Inc, Hanover, Massachusetts
Sheet Metal Union Local 17.

PELV-100
February 2024



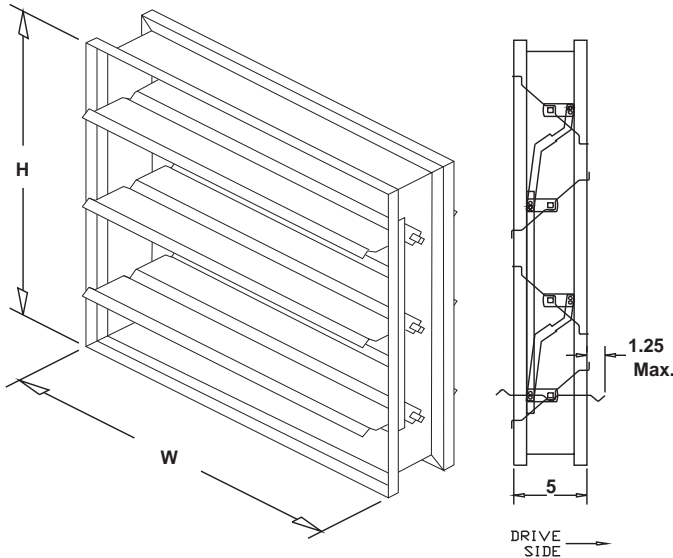

VCD-23

Low Leakage Control Damper

Application & Design

The model VCD-23 is a low leakage control damper for application as an automatic control or manual balancing damper. This model is intended for applications in low to medium pressure and velocity systems. A wide range of electric and pneumatic actuators are available. Non-jackshafted dampers will be supplied with a blade drive lever for internal actuator mounting. When external actuator mounting is specified in which case an extension pin with clip kit will be provided. Note: The extension pin with clip kit includes the extension pin and clip.

RATINGS

Pressure: 5 in. wg
Velocity: 3,000 ft/min
Leakage: Class 1A @ 1 in. wg, Class 1 @ 4 in. wg
Temperature: 200.0 F-250.0 F. Consult factory for higher temperatures.

Installation instructions available at www.greenheck.com.

Notes: All dimensions shown are in units of inches.

W & H furnished approximately 0.25 in. undersized and only refer to damper dimensions (sleeve thickness is not included).

Electrical accessory wiring terminates at the accessory.
Field wiring is required to individual components.

CONSTRUCTION FEATURES

Blade Action:	Opposed	Frame Thickness (ga):	16
Frame Type:	Channel	Actuator Type:	120 VAC
Material:	Galvanized	Actuator Mount:	Internal
Axle Material:	Steel	Actuator Location:	Left Side
Axle Bearings:	Synthetic	Fail Position:	Open
Linkage Material:	Steel	Cycle:	60 Cycle
Blade Seal:	TPE	Jackshafting:	No Preference
Jamb Seal Mat.:	304 SS	Auxiliary Switches:	Yes
Sizing:	Nominal	Temp. Rating (F):	180



ID #	Tag	Qty	W (in.)	H (in.)	Drive Arr.	Actuator	Act. Qty.
1-1		1	38.000	18.000	Drive-CC-11-1FIL-0	FSNF120-S	1
1-2		1	26.000	18.000	Drive-CC-11-1FIL-0	TFB120-S	1
1-3		1	32.000	18.000	Drive-CC-11-1FIL-0	TFB120-S	1

Damper Drive Arrangements Job Summary -Start-

Drive Arrangement: Drive-CC-11-1FIL-0

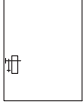

Damper Drive Arrangements Job Summary -End-

Low Leakage CONTROL DAMPER

Application and Design

The VCD-23 series is a ruggedly built low leakage control damper intended for application in low to medium pressure and velocity systems. A wide range of electric and pneumatic actuators are available.

Ratings (See page 4 for specific limitations)

Pressure: 2.5 - 5.0 in. wg (0.62 kPa - 1.2 kPa) - pressure differential.

Velocity: Up to 3000 fpm (15.2 m/s)

Leakage: Class 1A @ 1 in. wg (.25 kPa)
Class 1 @ up to 5 in. wg (1.2 kPa)

Temperature: Up to 250°F (121°C). Consult Greenheck for higher temperatures.

Construction	Standard	Optional
Frame Material	Galvanized Steel	Aluminum or 304SS
Frame Thickness	16 ga.	12 ga. (2.7mm)
Frame Type	5 in. x 1 in. Channel	-
Blade Material	Galvanized steel	Aluminum or 304SS
Blade Thickness	16 ga.	-
Blade Type	3V	-
Blade Seals	TPE	Silicone
Axle	1/2 in. dia. Plated Steel	304SS
Axle Bearings	Synthetic	Bronze, 304SS
Linkage Material	Plated Steel	304SS
Jamb Seal	304SS	-
Paint Finishes	Mill Finish	Baked Enamel, Epoxy, HI Pro Polyester, Industrial Epoxy, Permatector™

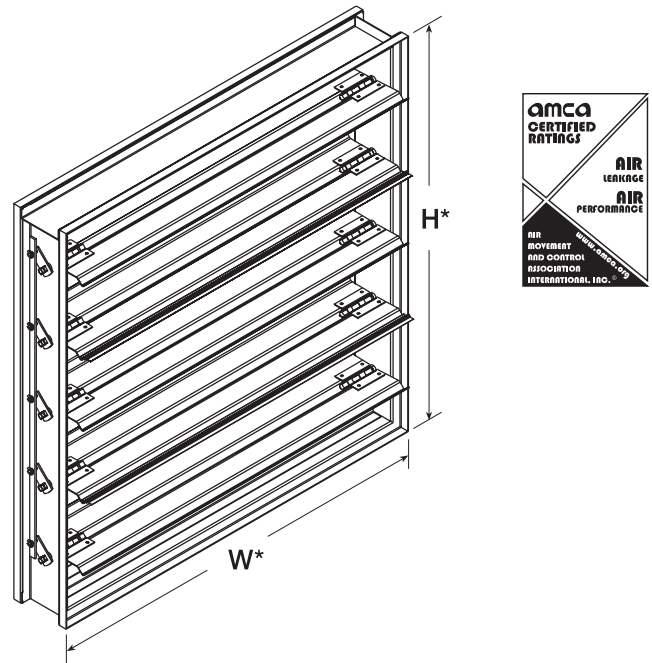

* W & H dimension furnished approximately 1/4 in. (6mm) undersize.

Flange Options

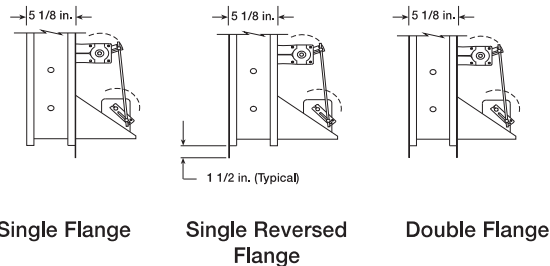

Single Flange

Single Reversed Flange

Double Flange

Size Limitations

W x H	Minimum Size	Maximum Size	
		Single Section	Multiple Section
Inches	6 x 6	48 x 74	Unlimited
mm	152 x 152	1219 x 1880	Unlimited

Blade Operation

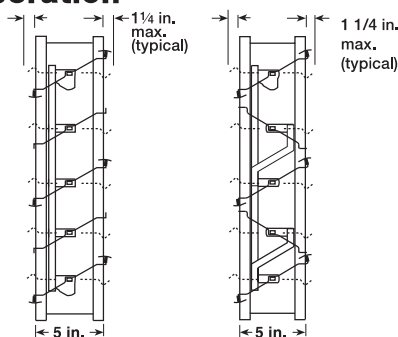

Parallel Blades

Opposed Blades

Features & Options

- Blade seals - pressure activated to produce tighter sealing.
- Linkage concealed in the frame
- Low profile head and sill are used on sizes less than 17 in. (432mm)
- Wide range of electric actuators, manual quadrant and pneumatic actuators available. Factory installation available.
- Sleeves available
- 5/8 in. - 2 in. (16mm - 51mm) flange available
- Retaining angles
- Transitions- R, C and O
- Open Close Indicator (OCI)
- Security bars

This pressure drop testing was conducted in accordance with AMCA Standard 500-D using the three configurations shown. All data has been corrected to represent standard air at a density of .075 lb/ft³(1.2 kg/m³). Actual pressure drop found in any HVAC system is a combination of many factors. This pressure drop information along with an analysis of other system influences should be used to estimate actual pressure losses for a damper installed in a given HVAC system.

AMCA Test Figures

Figure 5.2 Illustrates a ducted damper exhausting air into an open area. This configuration has a lower pressure drop than Figure 5.5 because entrance losses are minimized by a straight duct run upstream of the damper.

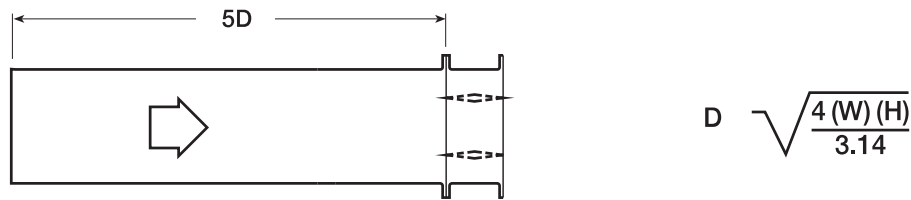

Figure 5.3 Illustrates a fully ducted damper. This configuration has the lowest pressure drop of the three test configurations because entrance and exit losses are minimized by straight duct runs upstream and downstream of the damper.

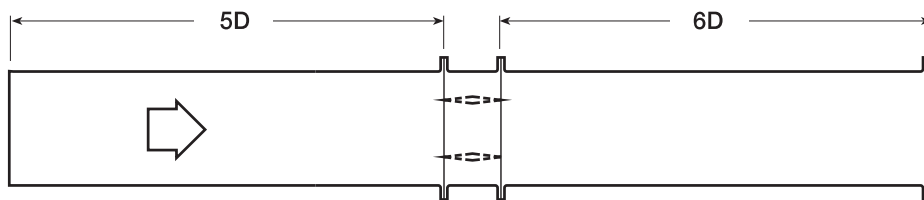
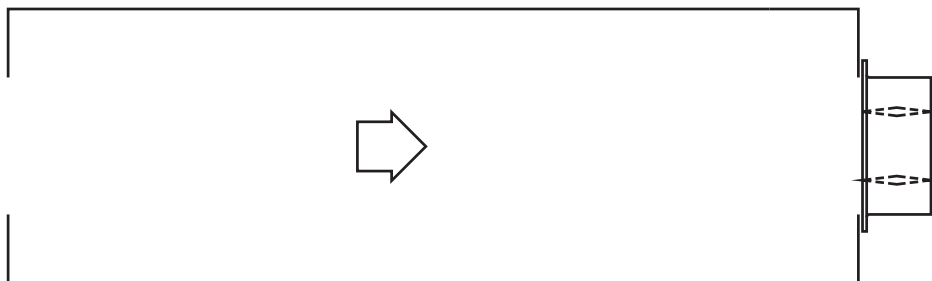

Figure 5.5 Illustrates a plenum mounted damper. This configuration has the highest pressure drop because of extremely high entrance and exit losses due to the sudden changes of area in the system.





Greenheck Fan Corporation certifies that the model VCD-23 shown herein is licensed to bear the AMCA Seal. The ratings shown are based on tests and procedures performed in accordance with AMCA Publication 511 and comply with the requirements of the AMCA Certified Ratings Programs. The AMCA Certified Ratings Seal applies to Air Leakage and Air Performance ratings.

AMCA 5.2

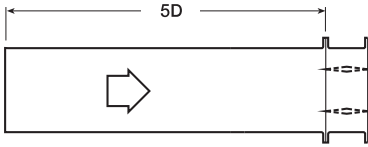

12 in. x 12 in. (305mm x 305mm)

Velocity (fpm)	Pressure Drop (in. wg)
500	0.01
1000	0.05
1500	0.11
2000	0.19
2500	0.29
3000	0.41
3500	0.55
4000	0.72

24 in. x 24 in. (610mm x 610mm)

Velocity (fpm)	Pressure Drop (in. wg)
500	0.01
1000	0.03
1500	0.06
2000	0.10
2500	0.16
3000	0.23
3500	0.30
4000	0.40

36 in. x 36 in. (914mm x 914mm)

Velocity (fpm)	Pressure Drop (in. wg)
500	0.01
1000	0.02
1500	0.05
2000	0.09
2500	0.14
3000	0.19
3500	0.27
4000	0.35

12 in. x 48 in. (305mm x 1219mm)

Velocity (fpm)	Pressure Drop (in. wg)
500	0.01
1000	0.04
1500	0.08
2000	0.15
2500	0.22
3000	0.32
3500	0.43
4000	0.56

48 in. x 12 in. (1219mm x 305mm)

Velocity (fpm)	Pressure Drop (in. wg)
500	0.01
1000	0.03
1500	0.07
2000	0.12
2500	0.18
3000	0.26
3500	0.36
4000	0.47

AMCA 5.3

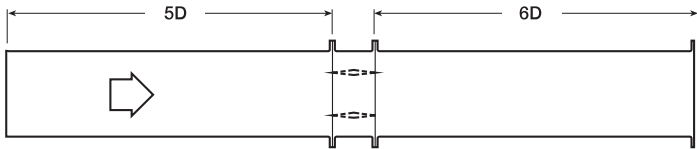

12 in. x 12 in. (305mm x 305mm)

Velocity (fpm)	Pressure Drop (in. wg)
500	0.01
1000	0.03
1500	0.08
2000	0.13
2500	0.20
3000	0.29
3500	0.40
4000	0.51

24 in. x 24 in. (610mm x 610mm)

Velocity (fpm)	Pressure Drop (in. wg)
500	0.01
1000	0.02
1500	0.04
2000	0.07
2500	0.11
3000	0.16
3500	0.21
4000	0.28

36 in. x 36 in. (914mm x 914mm)

Velocity (fpm)	Pressure Drop (in. wg)
500	0.01
1000	0.02
1500	0.03
2000	0.06
2500	0.09
3000	0.13
3500	0.19
4000	0.25

12 in. x 48 in. (305mm x 1219mm)

Velocity (fpm)	Pressure Drop (in. wg)
500	0.01
1000	0.03
1500	0.07
2000	0.12
2500	0.18
3000	0.26
3500	0.36
4000	0.46

48 in. x 12 in. (1219mm x 305mm)

Velocity (fpm)	Pressure Drop (in. wg)
500	0.01
1000	0.03
1500	0.06
2000	0.10
2500	0.16
3000	0.22
3500	0.30
4000	0.39

AMCA 5.5

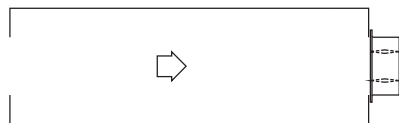

12 in. x 12 in. (305mm x 305mm)

Velocity (fpm)	Pressure Drop (in. wg)
500	0.03
1000	0.13
1500	0.30
2000	0.53
2500	0.82
3000	1.19
3500	1.62
4000	2.10

24 in. x 24 in. (610mm x 610mm)

Velocity (fpm)	Pressure Drop (in. wg)
500	0.03
1000	0.12
1500	0.26
2000	0.47
2500	0.75
3000	1.04
3500	1.41
4000	1.90

36 in. x 36 in. (914mm x 914mm)

Velocity (fpm)	Pressure Drop (in. wg)
500	0.02
1000	0.10
1500	0.22
2000	0.40
2500	0.62
3000	0.90
3500	1.23
4000	1.62

12 in. x 48 in. (305mm x 1219mm)

Velocity (fpm)	Pressure Drop (in. wg)
500	0.03
1000	0.12
1500	0.27
2000	0.47
2500	0.75
3000	1.07
3500	1.45
4000	1.91

48 in. x 12 in. (1219mm x 305mm)

Velocity (fpm)	Pressure Drop (in. wg)
500	0.03
1000	0.12
1500	0.28
2000	0.49
2500	0.77
3000	1.12
3500	1.53
4000	2.01

Air leakage is based on operation between 32°F (0°C) and 120°F (49°C).

Tested for leakage in accordance with ANSI/AMCA Standard 500-D, Figure 5.5.

Tested for air performance in accordance with ANSI/AMCA Standard 500-D, Figures 5.2, 5.3 and 5.5.

Torque

Data are based on a torque of 5.0 in.lb./ft² (0.56 N·m) applied to close and seat the damper during the test.

VCD-23	Leakage Class*	
Maximum Damper Width	1 in. wg (0.25 kPa)	4 in. wg (1 kPa)
48 in. (1219mm)	1A	1



Greenheck Fan Corporation certifies that the model VCD-23 shown herein is licensed to bear the AMCA Seal. The ratings shown are based on tests and procedures performed in accordance with AMCA Publication 511 and comply with the requirements of the AMCA Certified Ratings Programs. The AMCA Certified Ratings Seal applies to Air Leakage and Air Performance ratings.

*Leakage Class Definitions

The *maximum* allowable leakage is defined by AMCA as the following:

- Leakage Class 1A - 3 cfm/ft² @ 1 in. wg (class 1A is only defined at 1 in. wg).
- Leakage Class 1
 - 4 cfm/ft² @ 1 in. wg
 - 8 cfm/ft² @ 4 in. wg
 - 11 cfm/ft² @ 8 in. wg
 - 12.6 cfm/ft² @ 10 in. wg

Velocity Limitations

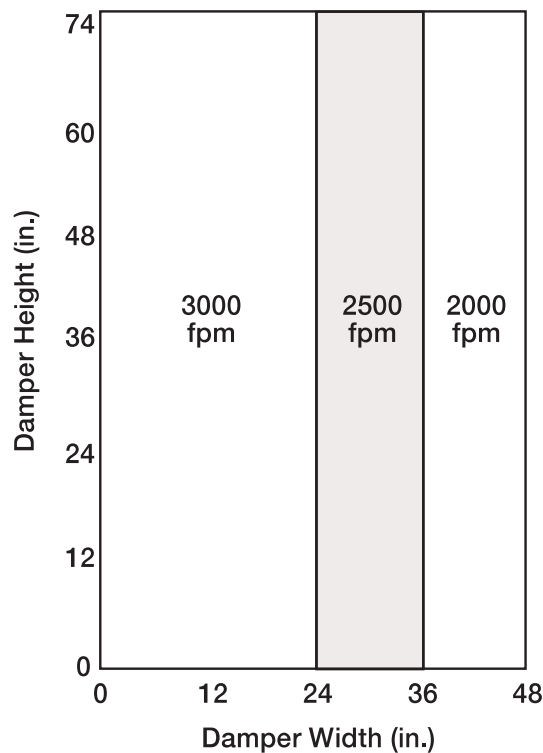

ASSEMBLY

SPECIFICATIONS

Multi-Section Assembly

Dampers larger than the maximum single section size, will be made up of a multiple of equal size sections. Multiple section dampers can be jackshafted together so that all sections operate together as shown below.

NOTE: Dampers larger than 48 in. x 74 in. (1219mm x 1880mm) are not intended to be structurally self supporting. Additional horizontal bracing is recommended to support the weight of the damper and vertical bracing should be installed as required to hold against system pressure.

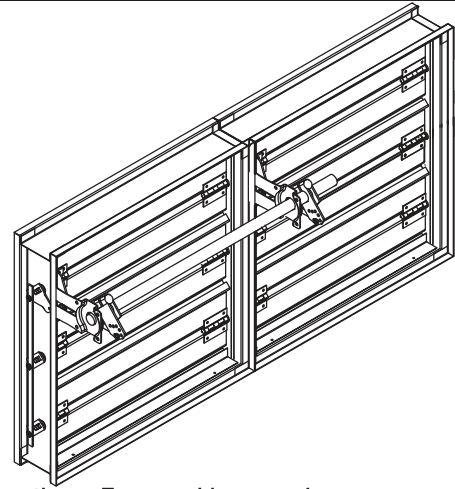

Face and Bypass Configurations

VCD-23 series control dampers can be assembled for face and bypass configurations. Face and bypass dampers are available in vertical, horizontal and right angle arrangements as shown below.

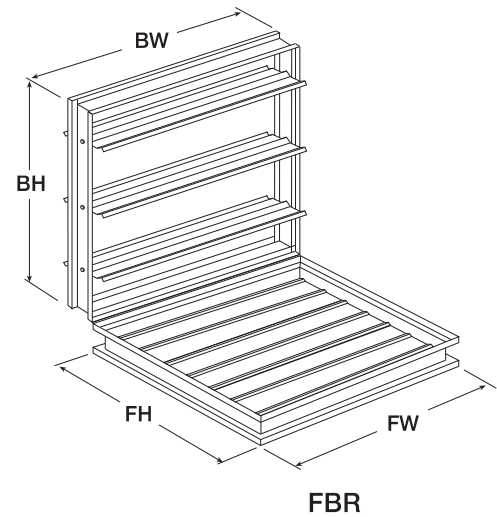
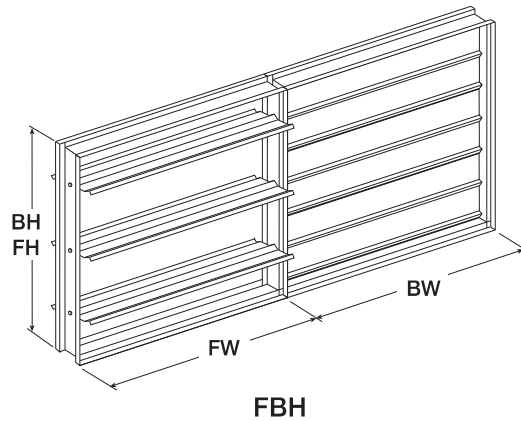
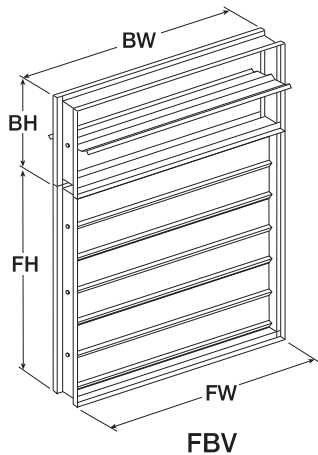

Specifications

Control dampers meeting the following specifications shall be furnished and installed where shown on plans and/or as described in schedules.

Damper blades shall be 16 ga. (1.5mm) galvanized steel 3 Vee type with three longitudinal grooves for reinforcement. Blades shall be completely symmetrical relative to their axle pivot point, presenting identical resistance to airflow and operation in either direction through the damper (blades that are non-symmetrical relative to their axle pivot point or utilize blade stops larger than 1/2 in. [13mm] are unacceptable). Blade seals shall be TPE. Linkage shall be blade-to-blade concealed in jamb (out of the airstream) to protect linkage and reduce pressure drop and noise.

Damper frame shall be 16 ga. (1.5mm) galvanized steel formed into a structural hat channel shape with reinforced

corners to meet 11 ga. (3.1mm) criteria. Bearings shall be corrosion resistant, permanently lubricated, synthetic (acetal) sleeve type rotating in extruded holes in the damper frame for maximum service. Axles shall be square and positively locked into the damper blade. Jamb seals shall be flexible stainless steel compression type to prevent leakage between blade end and damper frame.

The Damper Manufacturer's submittal data shall certify all air leakage and air performance pressure drop data is licensed in accordance with the AMCA Certified Ratings Program for Test Figures 5.2, 5.3 and 5.5. Damper air performance data shall be developed in accordance with the latest edition of AMCA Standard 500-D.

Basis of design is Greenheck's model VCD-23.



Drive Arrangement Definition

On multi-blade dampers (except vertical blade and Face & Bypass), they are given a drive arrangement code that helps describe the construction of the damper. The following breaks down what each number and letter represents.

22-2FEL-2

① ② ③ ④ ⑤ ⑥ ⑦

- ① Number of sections wide
- ② Number of sections high
- ③ Number of actuators or manual quadrants
- ④ Who supplies the actuators or manual quadrants
F - Factory
C - Customer Supplied (field mounted)
- ⑤ Actuator or manual quadrant mounting
E - External
I - Internal
B - Both internal and external
- ⑥ Actuator or manual quadrant location
L - Left hand drive
R - Right hand drive
B - Both right and left
- ⑦ Number of jackshafts

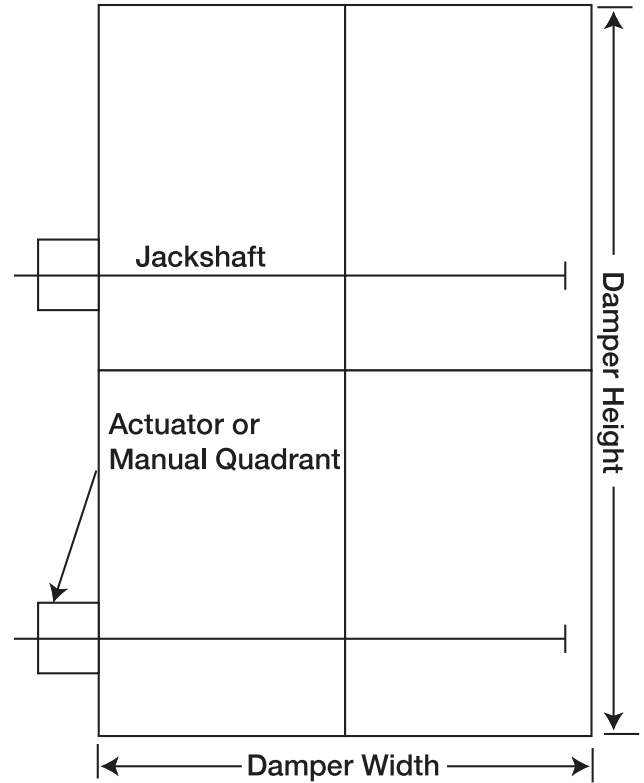

On vertical blade and face & bypass dampers, they are given a configuration ID number that helps describe the construction of the damper. See the following examples:

Model	Drive Arrangement Prefix
AMD-23, 33, 42	AMD
AMD-42V	VB
DFD-210, 230; DFDAF-310; DFDTF-210; SEDFD-210	MLS
FBH & FBV	FB
FSD, OFSD, CFSD, SMD, SEFSD, SSFSD, SESMD, SSSMD series (except vertical blade models)	MLS
FSD-311V, SMD-301V	VB
GFSD series	GFSD
ICD series	CC
IMO series	MLS
VCD series (except vertical blade models)	CC
VCD-xxV (vertical blade models)	VB

Belimo FSNF-120, 120S, 24, 24S, 230, 230S Two Position Actuators

Application

The type FSNF spring-return actuator is intended for the operation of smoke and combination fire and smoke dampers in ventilation and air-conditioning systems. The actuator will meet requirements of UL555 and UL555S when tested as an assembly with damper and will meet requirements of UBC for 15 second opening and closing. The actuator has 2 SPDT auxiliary switches, one at each end of the stroke.

Torque rating (at rating voltage)

70 in. lb (7.9N•m) minimum from 32°F to 350°F (0°C to 177°C)

Timing (at rated torque and voltage)

Motor: Less than 15 seconds, 32°F to 350°F (0°C to 177°C)

Spring : Less than 15 seconds

Environmental Protection Ratings:

Nema 1

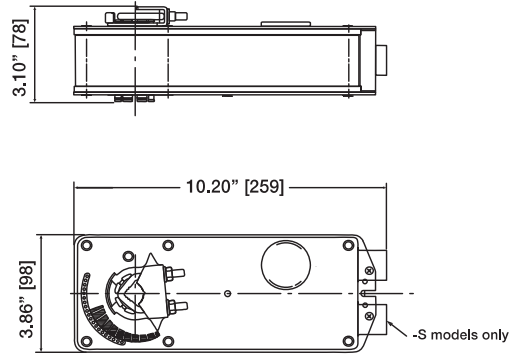

Model	Auxiliary Switch	Power Consumption		Voltage Input in Vac
		Running	Holding	
FSNF120	No	27 VA	10 VA	120 VAC, 50/60Hz
FSNF120S	Yes			
FSNF24	No	27 VA	10 VA	24 VAC, 50/60 Hz
FSNF24S	Yes			
FSNF230	No	27 VA	10 VA	230 VAC, 50/60 Hz
FSNF230S	Yes			

For Vertical Blade

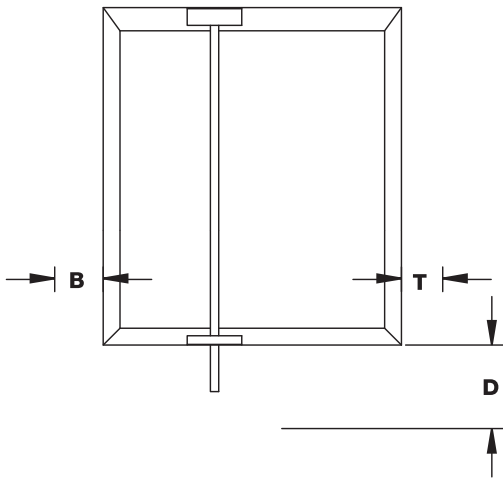

Width	"T"	"B"	"D"
≥6 (152) to <10 (254)	0	12.75 (324)	6 (152)
≥10 (254) to <18 (457)	0	2 (51)	6 (152)
≥18 (457)	0	0	6 (152)

Dimensions are in inches (mm).

For Horizontal Blade

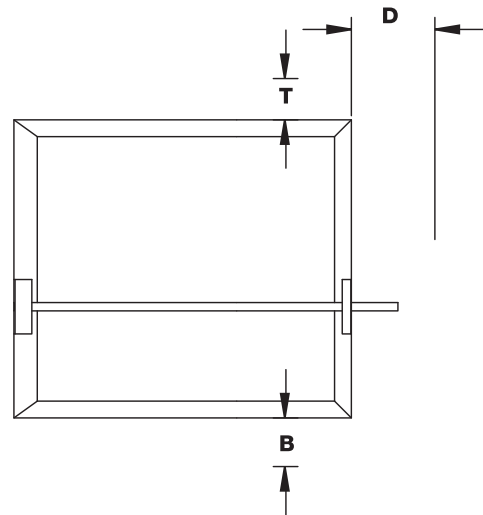

Height			Piggyback	
	"T"	"B"	"D"	"D"
≥6 (152) to <10 (254)	0	12.75 (324)	6 (152)	9 (229)
≥10 (254) to <18 (457)	0	2 (51)	6 (152)	9 (229)
≥18 (457)	0	0	6 (152)	9 (229)

Dimensions are in inches (mm).

Due to continuous product improvement, the actuator manufacturer reserves the right to change specifications without notice. For the most up-to-date information and maintenance, go to www.belimo.us

Belimo TFB120, 120-S, 24, and 24-S Actuators

Application

The TFB series actuators provide true spring return operation for reliable fail-safe application and positive close off on air tight dampers. The spring return system provides consistent torque to the damper with and without power applied to the actuator. The TFBxxx-S version is provided with one built in auxiliary switches.

Torque rating (at rating voltage)

22 in. lb (2.5N•m) constant

Timing (at rated torque and voltage)

Motor: Less than 75 seconds; (TFB24-SR & -S is 95 seconds)

Spring : Less than 25 seconds

Environmental Protection Ratings:

Nema 2

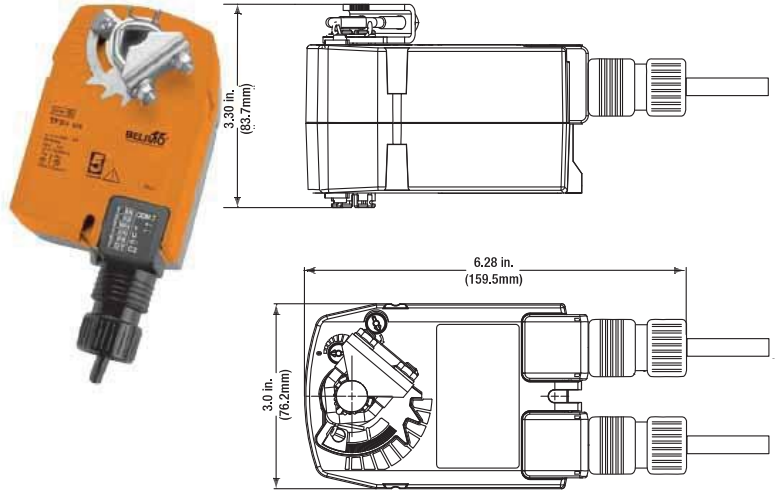

Model	Auxiliary Switch	Power Consumption		Voltage Input in Vac
		Running	Holding	
TFB24	No	2W	1.3W	24 VAC, 24 VDC
TFB24-S	Yes			
TFB120	No	2.5W	1.3W	100-240 VAC
TFB120-S	Yes			

Space Envelopes for VCD Series

For Vertical Blade

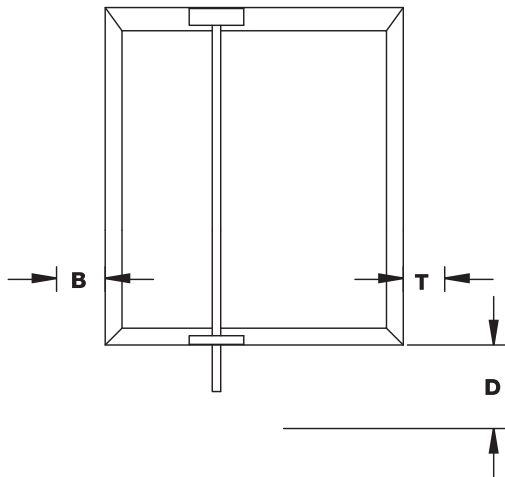

Width	"T"	"B"	"D"
≥6 (152) to <10 (254)	0	3.5 (89)	6 (152)
≥10 (254)	0	0	6 (152)

Dimensions are in inches (mm).

For Horizontal Blade

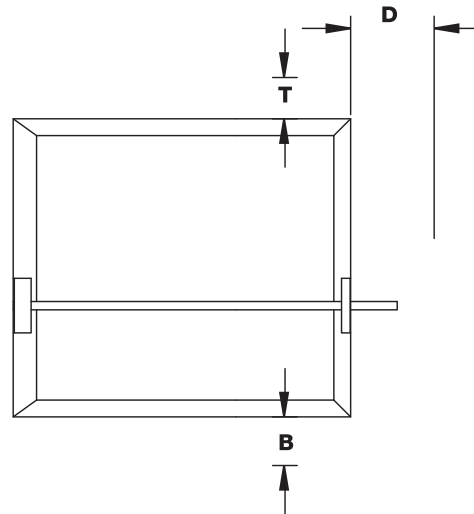

Height	"T"	"B"	"D"
≥6 (152) to <10 (254)	0	3.5 (89)	6 (152)
≥10 (254)	0	0	6 (152)

Dimensions are in inches (mm).

Due to continuous product improvement, the actuator manufacturer reserves the right to change specifications without notice. For the most up-to-date information and maintenance, go to www.belimo.us