

INSTALLATION DATA

BUCKLEY FIRE DAMPERS

MODEL 150 TYPE, TYPE A & B

FOR DRY WALL

Detail of opening preparation and fire damper installation.

Wall rating - 2 hour

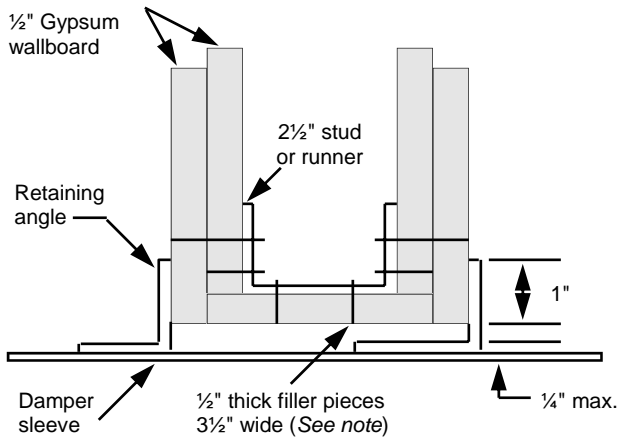

Wall rating - 1 hour

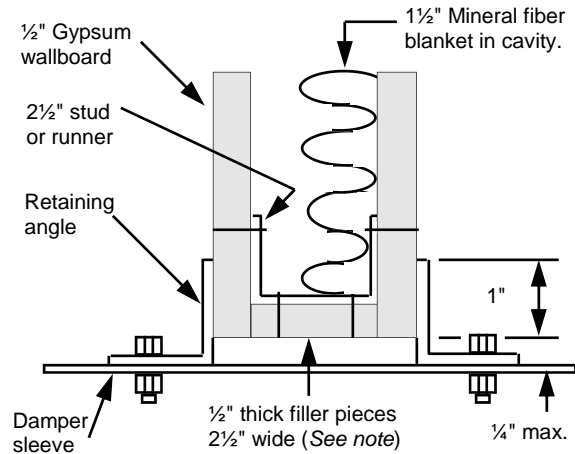

Note: Filler pieces to be installed around entire opening. Screwed 12" O.C. to web of runners and studs.

Metal stud framing for Fire Dampers in drywall partitions.

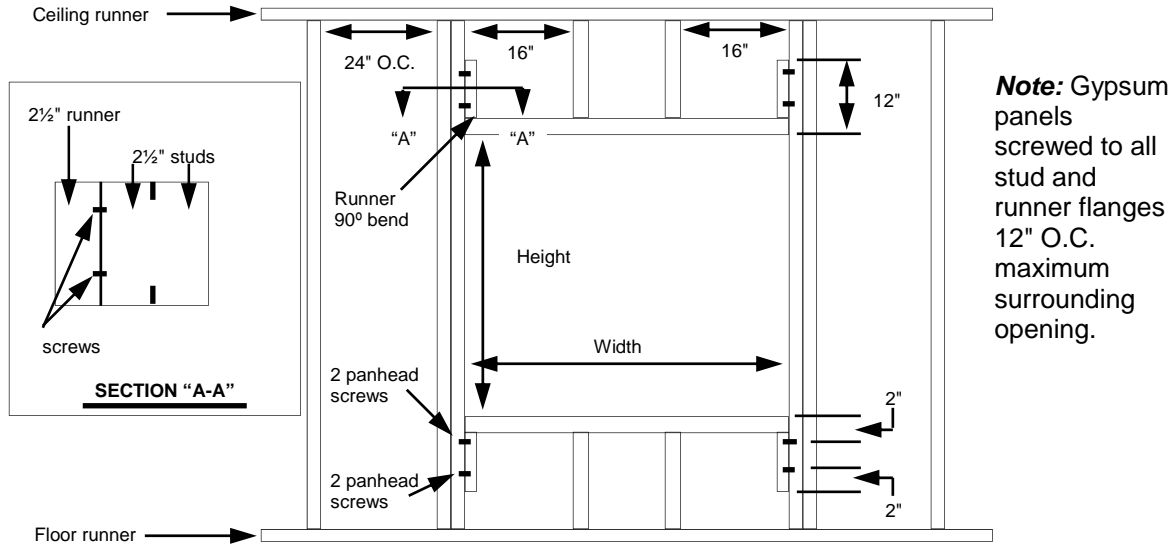

To maintain Buckley's policy of continuous improvement, we reserve the right to change prices, specifications, ratings or dimensions without notice or obligation. **Manufactured by Sheet Metal Union Local 17.**

MANUFACTURED BY: Buckley Associates, Inc. HANOVER, MA

Visit us on the World Wide Web at: <http://www.buckleyonline.com>

