

# SUBMITTAL DATA

## BUCKLEY FIRE DAMPERS

HORIZONTAL & VERTICAL, MODEL 150, TYPE CR ROUND, U.L. CLASSIFIED

### For use in Static Systems

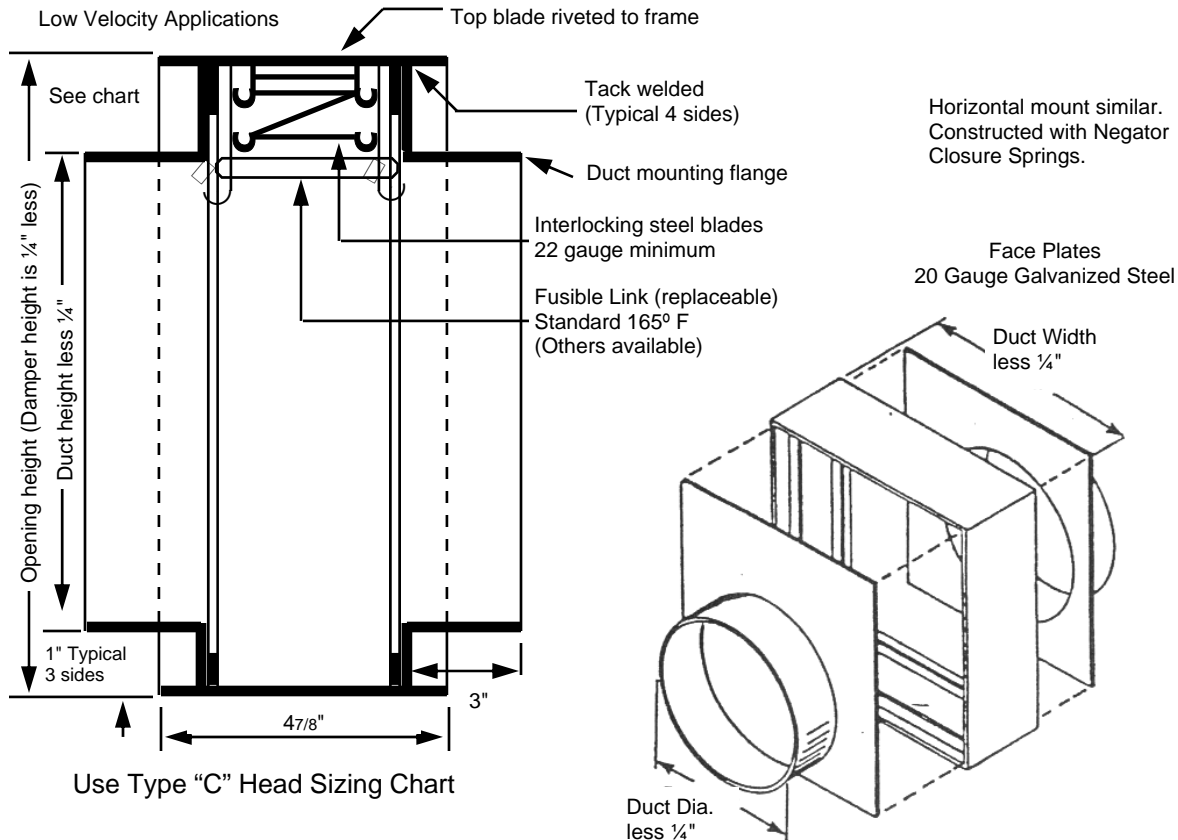

Single Selection Size Availability		
	Vertical	Horizontal
	Width x Height	Width x Height
<b>Minimum</b>	4" Dia.	4" Dia.
<b>Maximum Section</b>	54" Dia. 58" W x 54" H	42" Dia. 46" W x 42" H
<b>Maximum Duct Size</b>	54" Dia. 58" W x 54" H	42" Dia. 46" W x 42" H

### Look for this Label

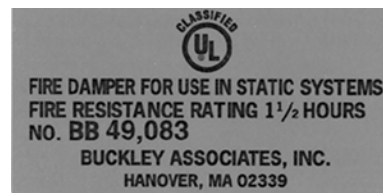

**Material:** Standard construction Galvanized Steel. Underwriters laboratories classified for use in 2 hour fire partitions. Meets NFPA-90A & UL555.

To maintain Buckley's policy of continuous improvement, we reserve the right to change prices, specifications, ratings or dimensions without notice or obligation. **Manufactured by Sheet Metal Union Local 17.**

**MANUFACTURED BY: Buckley Associates, Inc. HANOVER, MA**

Visit us on the World Wide Web at: <http://www.buckleyonline.com>

