

SUBMITTAL DATA

BUCKLEY FIRE DAMPERS

HORIZONTAL & VERTICAL, MODEL 150 TYPE B, U.L. CLASSIFIES

For use in Static Systems

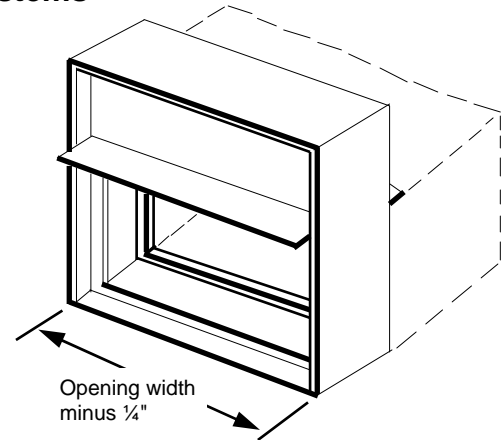
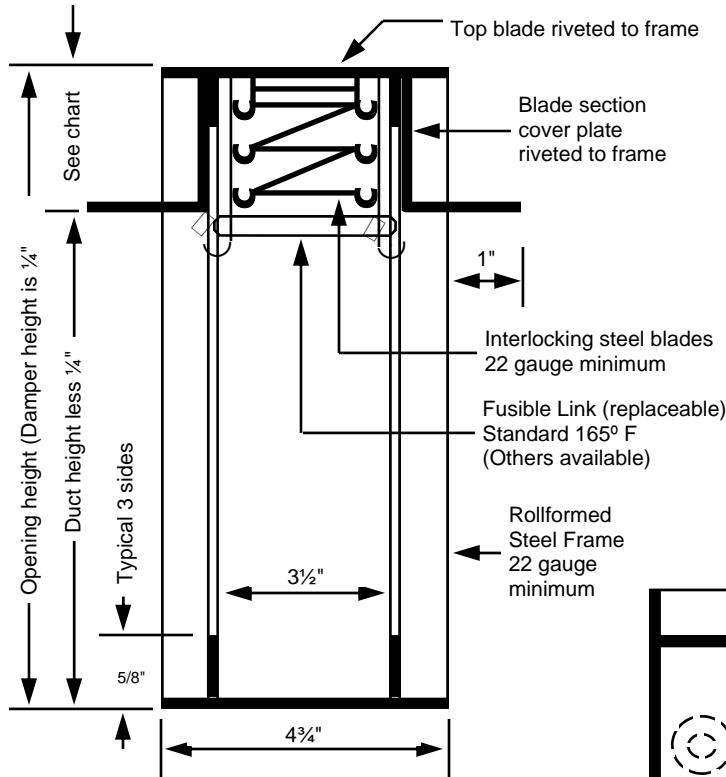

HORIZONTAL MOUNT

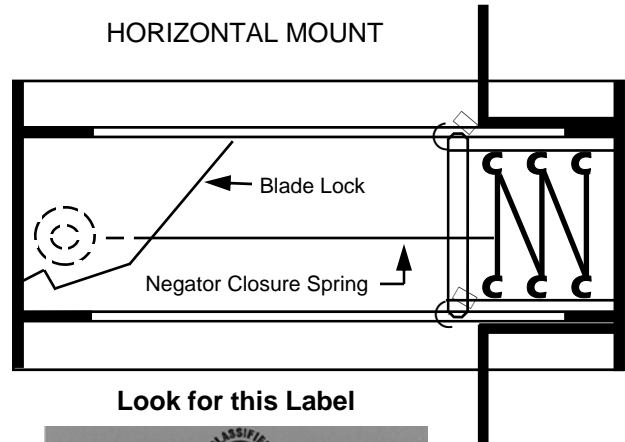

Look for this Label

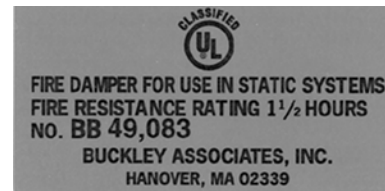

Single Selection Size Availability				
	Vertical		Horizontal	
	Width	Height	Width	Height
Minimum	4"	4"	4"	4"
Maximum Section	60"	60"	48"	48"
Maximum Duct Size	60"	55"	48"	43"

For multiple assembly sizes consult U.L. Listing Card or U.L. Fire Resistance Index.

Material: Standard construction Galvanized Steel. Underwriters laboratories classified for use in 2 hour fire partitions. Meets NFPA-90A & UL555. See attached sheet for schedule of models and sizes.

To maintain Buckley's policy of continuous improvement, we reserve the right to change prices, specifications, ratings or dimensions without notice or obligation. **Manufactured by Sheet Metal Union Local 17.**

MANUFACTURED BY: Buckley Associates, Inc. HANOVER, MA

Visit us on the World Wide Web at: <http://www.buckleyonline.com>

