

# Roof Upblast/Sidewall Exhaust Size-180: CUBE • CUE • USGF

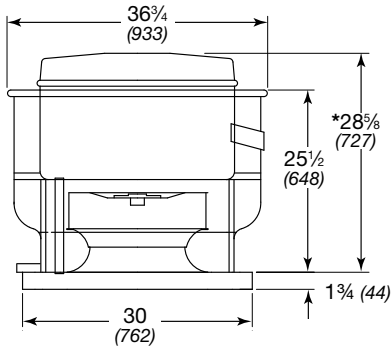

### Direct Drive RPM

- C-860 RPM
- B-1140 RPM
- VG-1000 RPM

All dimensions in inches (millimeters), weight in pounds (kilograms).  
 \* May be greater depending on motor.  
 ^Weight shown is largest cataloged open drip-proof motor.

	CUBE	CUE	USGF
^Approximate Weight	126 (57)	142 (64)	190 (86)
Damper Size	18 x 18 (457 x 457)	N/A	N/A
Roof/Wall Opening	20 1/2 x 20 1/2 (521 x 521)		
Wall Opening with a Curb Through Wall	30 x 30 (762 x 762)	N/A	N/A

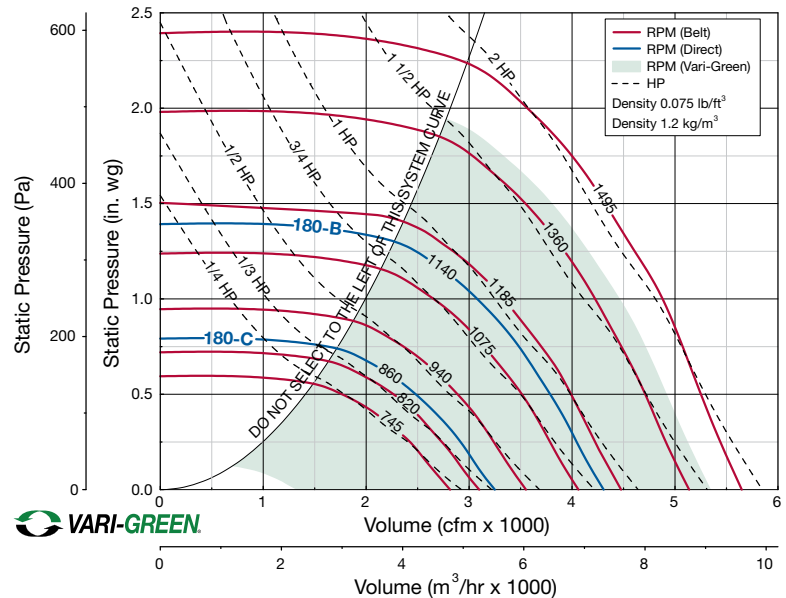

Motor HP		Fan RPM	Static Pressure in Inches wg										
Belt	Direct		0	0.125	0.25	0.5	0.75	1	1.25	1.5	1.75	2	
<b>180</b>													
1/4	VG-3/4 or 1	745	CFM	2815	2617	2448	1763						
			BHP	0.22	0.24	0.26	0.25						
1/3	VG-3/4 or 1	820	CFM	3098	2916	2759	2257						
			BHP	0.30	0.32	0.34	0.34						
1/2	C-1/2	860	CFM	3249	3074	2922	2474						
			BHP	0.34	0.37	0.39	0.40						
1/2	VARI-GREEN	940	CFM	3551	3389	3243	2879	2363					
			BHP	0.45	0.47	0.49	0.52	0.50					
3/4	VG-1	1000	CFM	3778	3625	3486	3190	2738					
			BHP	0.54	0.57	0.59	0.63	0.62					
3/4	VG-1	1075	CFM	4061	3919	3786	3554	3141	2652				
			BHP	0.67	0.70	0.73	0.78	0.78	0.75				
1	B-1	1140	CFM	4307	4173	4045	3822	3470	3072	2477			
			BHP	0.80	0.83	0.86	0.91	0.93	0.92	0.85			
1	VG-2	1185	CFM	4477	4348	4224	4005	3703	3336	2841			
			BHP	0.90	0.93	0.96	1.01	1.04	1.04	0.99			
1 1/2	VG-2	1275	CFM	4817	4697	4578	4369	4163	3799	3437	2930		
			BHP	1.12	1.15	1.19	1.24	1.30	1.30	1.28	1.22		
1 1/2	VG-2	1360	CFM	5138	5026	4913	4710	4532	4232	3912	3537	3023	
			BHP	1.36	1.39	1.43	1.49	1.56	1.58	1.58	1.54	1.46	
2	X	1495	CFM	5648	5546	5443	5254	5082	4921	4598	4313	3983	3564
			BHP	1.80	1.84	1.89	1.96	2.02	2.10	2.10	2.10	2.06	1.99
2	X	1495	Sones	28	27	27	26	25	25	24	23	22	21
			Sones	28	27	27	26	25	25	24	23	22	21

MAXIMUM BHP AT A GIVEN RPM = (RPM/1167)<sup>3</sup>  
 MAXIMUM RPM = 1495  
 TIP SPEED (ft/min) = RPM x 4.843  
 MAXIMUM MOTOR FRAME SIZE = 184T  
 AVERAGE DISCHARGE VELOCITY (FPM) = CFM/2.92

Performance certified is for installation type A: Free inlet, Free outlet. Power rating (Bhp) does not include transmission losses. Performance ratings do not include the effects of appurtenances (accessories). The sound ratings shown are loudness values in fan sones at 5 ft. (1.5 m) in a hemispherical free field calculated per AMCA Standard 301. Values shown are for installation type A: Free inlet hemispherical sone levels.