

BSQ 70 - Belt Drive

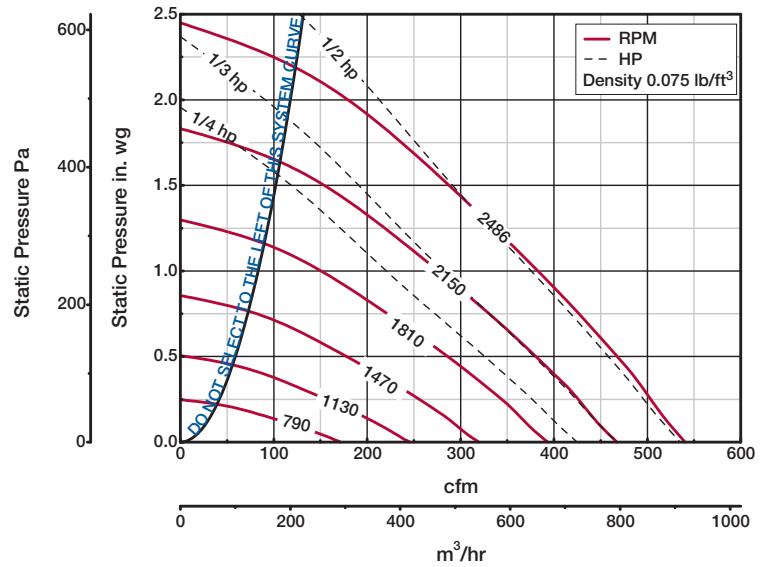
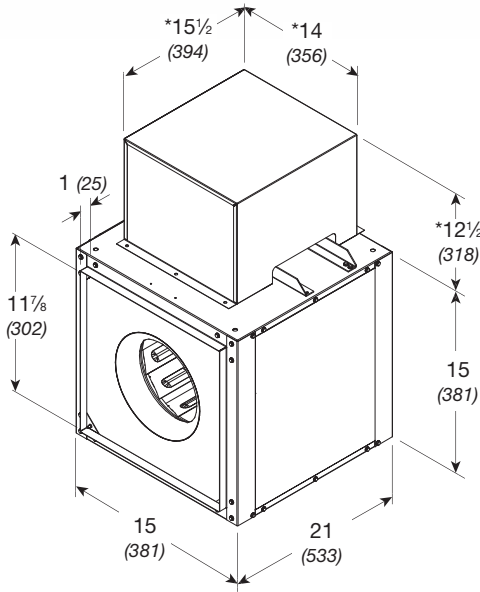

Damper size = 12 x 12 (305 x 305)
 Unit weight** = 76 (34)
 Housing thickness = 18 ga

Dimensions shown in inches (millimeters) and weight is shown in pounds (kilograms).
 *Motor cover is optional. Size may be greater depending on motor.
 **Weight shown is largest cataloged Open Drip Proof motor.

Model Number	Motor HP	Fan RPM	CFM / Static Pressure in Inches wg											
			0.125	0.250	0.500	0.625	0.750	1.000	1.250	1.500	1.750	2.000		
70														
70-4	1/4	1050	CFM	184	129									
			BHP	0.039	0.037									
			Sones	8.0	7.5									
		1313	CFM	251	211	117								
			BHP	0.077	0.076	0.068								
			Sones	11.0	10.4	9.2								
		1445	CFM	284	249	169	122							
			BHP	0.103	0.102	0.097	0.09							
			Sones	12.8	12.3	10.7	10.3							
		1577	CFM	314	284	213	175	131						
			BHP	0.13	0.13	0.13	0.12	0.12						
			Sones	14.9	14.6	12.7	11.9	11.4						
1709	CFM	345	318	254	220	184	97							
	BHP	0.17	0.17	0.17	0.16	0.16	0.14							
	Sones	16.1	15.9	14.5	13.9	13.3	12.4							
1840	CFM	375	351	293	262	231	159							
	BHP	0.21	0.21	0.21	0.21	0.20	0.19							
	Sones	17.3	17.0	16.4	16.0	15.4	14.5							
1972	CFM	405	384	331	302	273	212	142						
	BHP	0.26	0.26	0.26	0.25	0.25	0.24	0.22						
	Sones	19.2	19.1	18.6	18.2	17.9	17.7	16.5						
70-3	1/3	2072	CFM	428	408	360	332	305	249	184	103			
			BHP	0.30	0.30	0.30	0.30	0.29	0.29	0.27	0.24			
			Sones	20	20	19.9	19.5	19.1	18.5	18.2	16.8			
		2172	CFM	450	431	387	361	335	282	224	161			
			BHP	0.34	0.35	0.35	0.34	0.34	0.33	0.32	0.30			
			Sones	21	21	21	21	20	19.7	19.2	18.8			
70-5	1/2	2329	CFM	486	467	428	406	381	332	283	225	166		
			BHP	0.43	0.43	0.43	0.43	0.42	0.42	0.41	0.39	0.36		
			Sones	23	23	23	23	23	22	21	20	21		
		2486	CFM	521	504	468	447	426	380	334	287	232	176	
			BHP	0.52	0.52	0.52	0.52	0.52	0.51	0.50	0.49	0.47	0.44	
			Sones	25	25	25	25	25	24	23	22	22	23	

MAX Bhp AT A GIVEN RPM = (rpm/3084)³
 MAXIMUM RPM = 2486
 TIP SPEED (ft/min) = rpm x 2.928
 MAX NEMA MOTOR FRAME SIZE = 145T
 OUTLET VELOCITY (ft/min) = 1.0212 x cfm

Performance certified is for installation type B: Free inlet, Ducted outlet. Power rating (Bhp) does not include transmission losses. Performance ratings do not include the effects of appurtenances (accessories).
 The sound ratings shown are loudness values in fan sones at 1.5 m (5 feet) in a hemispherical free field calculated per AMCA International Standard 301. Values shown are for installation type B: free inlet hemispherical sone levels.