

# BSQ 240 - Belt Drive

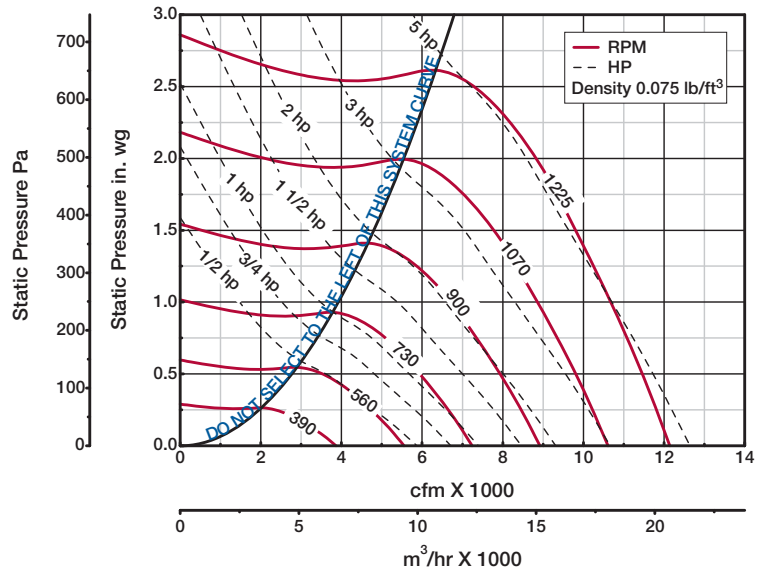
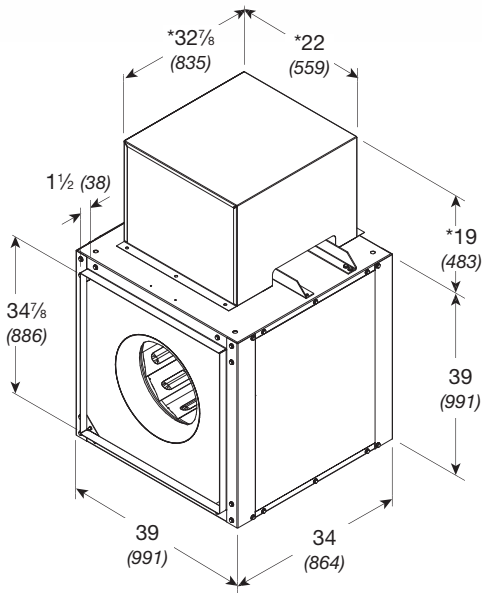

Damper size = 35 x 35 (889 x 889)  
 Unit weight\*\* = 415 (188)  
 Housing thickness = 18 ga

Dimensions shown in inches (millimeters) and weight is shown in pounds (kilograms).  
 \*Motor cover is optional. Size may be greater depending on motor.  
 \*\*Weight shown is largest cataloged Open Drip Proof motor.

Model Number	Motor HP	Fan RPM	CFM / Static Pressure in Inches wg										
			0.125	0.250	0.500	0.750	1.000	1.250	1.500	1.750	2.000	2.500	
<b>240</b>													
240-5	1/2	500	CFM	4518	4001								
			BHP	0.33	0.35								
			Sones	10.7	10.2								
		569	CFM	5269	4833	3685							
			BHP	0.48	0.51	0.51							
			Sones	12.3	11.8	10.8							
240-7	3/4	651	CFM	6132	5768	4946							
			BHP	0.70	0.74	0.78							
			Sones	14.3	13.9	12.9							
240-10	1	684	CFM	6475	6135	5368	4273						
			BHP	0.81	0.85	0.90	0.89						
			Sones	15.2	14.9	13.8	12.6						
		717	CFM	6816	6498	5782	4884						
			BHP	0.93	0.97	1.03	1.03						
			Sones	16.2	15.9	14.9	13.6						
240-15	1 1/2	826	CFM	7935	7680	7086	6425	5604					
			BHP	1.41	1.45	1.54	1.59	1.58					
			Sones	19.5	19.5	18.7	17.4	16.2					
240-20	2	903	CFM	8720	8488	7960	7384	6756	5889				
			BHP	1.83	1.88	1.97	2.05	2.09	2.05				
			Sones	22	22	22	20	18.9	17.9				
240-30	3	969	CFM	9390	9174	8695	8176	7612	6962	6075			
			BHP	2.25	2.31	2.41	2.50	2.56	2.57	2.52			
			Sones	25	24	24	23	21	20	19.4			
		1034	CFM	10048	9845	9409	8936	8421	7881	7219	6268		
			BHP	2.73	2.79	2.90	3.01	3.08	3.14	3.11	3.03		
			Sones	28	27	27	26	23	22	22	21		
240-50	5	1098	CFM	10694	10503	10105	9660	9192	8695	8160	7510	6451	
			BHP	3.26	3.32	3.44	3.56	3.65	3.72	3.76	3.72	3.58	
			Sones	31	31	30	29	26	24	24	23	22	
		1225	CFM	11973	11802	11460	11070	10671	10245	9804	9345	8797	7124
			BHP	4.50	4.58	4.72	4.84	4.97	5.07	5.16	5.22	5.20	4.95
			Sones	41	40	38	37	34	31	28	28	28	26

MAX Bhp AT A GIVEN RPM = (rpm/706)<sup>3</sup>  
 MAXIMUM RPM = 1225  
 TIP SPEED (ft/min) = rpm x 6.414  
 MAX NEMA MOTOR FRAME SIZE = 215T  
 OUTLET VELOCITY (ft/min) = 0.1192 x cfm

Performance certified is for installation type B: Free inlet, Ducted outlet. Power rating (Bhp) does not include transmission losses. Performance ratings do not include the effects of appurtenances (accessories).  
 The sound ratings shown are loudness values in fan sones at 1.5 m (5 feet) in a hemispherical free field calculated per AMCA International Standard 301. Values shown are for installation type B: free inlet hemispherical sone levels.