

# BSQ 120 - Belt Drive

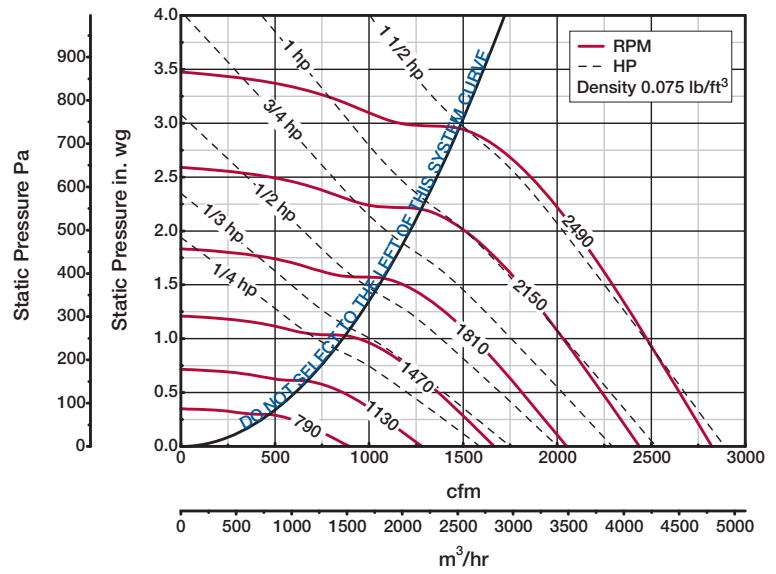
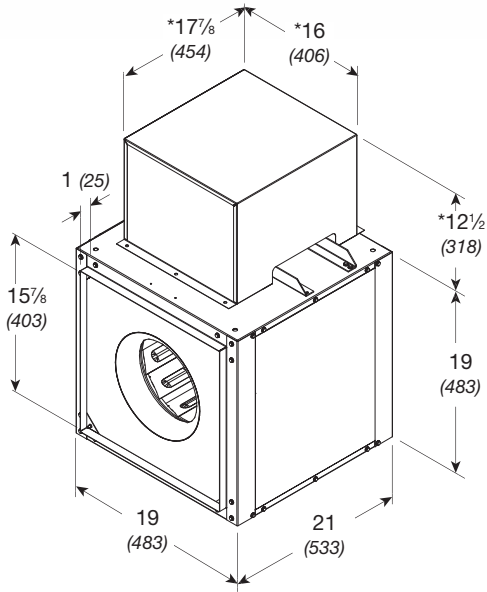

Damper size = 16 x 16 (406 x 406)  
 Unit weight\*\* = 97 (44)  
 Housing thickness = 18 ga

Dimensions shown in inches (millimeters) and weight is shown in pounds (kilograms).  
 \*Motor cover is optional. Size may be greater depending on motor.  
 \*\*Weight shown is largest cataloged Open Drip Proof motor.

Model Number	Motor HP	Fan RPM	CFM / Static Pressure in Inches wg										
			0.125	0.375	0.750	1.000	1.250	1.500	2.000	2.250	2.500	2.750	
<b>120</b>													
120-4	1/4	1000	CFM	1026	783								
			BHP	0.096	0.102								
			Sones	7.7	7.5								
		1367	CFM	1471	1311	1020							
			BHP	0.24	0.25	0.26							
			Sones	10.9	10.5	10.0							
120-3	1/3	1437	CFM	1555	1403	1145							
			BHP	0.28	0.29	0.30							
			Sones	11.7	11.3	10.4							
		1506	CFM	1636	1492	1252	1027						
			BHP	0.32	0.33	0.35	0.34						
			Sones	12.5	12.1	11.1	10.2						
120-5	1/2	1615	CFM	1764	1631	1418	1245						
			BHP	0.39	0.41	0.43	0.43						
			Sones	13.8	13.6	12.4	11.8						
		1724	CFM	1892	1767	1571	1423	1241					
			BHP	0.47	0.49	0.52	0.52	0.52					
			Sones	15.2	15.3	13.8	13.6	12.4					
120-7	3/4	1974	CFM	2183	2075	1908	1791	1663	1518				
			BHP	0.71	0.73	0.76	0.78	0.78	0.78				
			Sones	19.0	18.9	17.6	16.9	16.4	15.7				
120-10	1	2073	CFM	2298	2195	2037	1928	1813	1683	1293			
			BHP	0.82	0.84	0.88	0.89	0.91	0.91	0.86			
			Sones	21	21	19.0	18.6	17.9	17.5	15.2			
		2172	CFM	2413	2314	2164	2062	1953	1836	1553			
			BHP	0.94	0.97	1.00	1.02	1.04	1.05	1.03			
			Sones	23	23	21	21	19.7	19.0	17.5			
120-15	1 1/2	2329	CFM	2594	2503	2363	2268	2171	2069	1841	1695	1477	
			BHP	1.16	1.19	1.22	1.25	1.27	1.28	1.29	1.28	1.23	
			Sones	26	26	24	23	23	22	21	19.9	18.8	
		2490	CFM	2779	2694	2563	2475	2387	2294	2093	1984	1852	1682
			BHP	1.41	1.44	1.49	1.51	1.54	1.55	1.58	1.58	1.57	1.53
			Sones	31	30	27	26	27	26	24	23	23	22

MAX Bhp at A GIVEN RPM = (rpm/2144)<sup>3</sup>  
 MAXIMUM RPM = 2490  
 TIP SPEED (ft/min) = rpm x 3.436  
 MAX NEMA MOTOR FRAME SIZE = 145T  
 OUTLET VELOCITY (ft/min) = 0.5805 x cfm

Performance certified is for installation type B: Free inlet, Ducted outlet. Power rating (Bhp) does not include transmission losses. Performance ratings do not include the effects of appurtenances (accessories).

The sound ratings shown are loudness values in fan sones at 1.5 m (5 feet) in a hemispherical free field calculated per AMCA International Standard 301. Values shown are for installation type B: free inlet hemispherical sone levels.