

BSQ 100 - Belt Drive

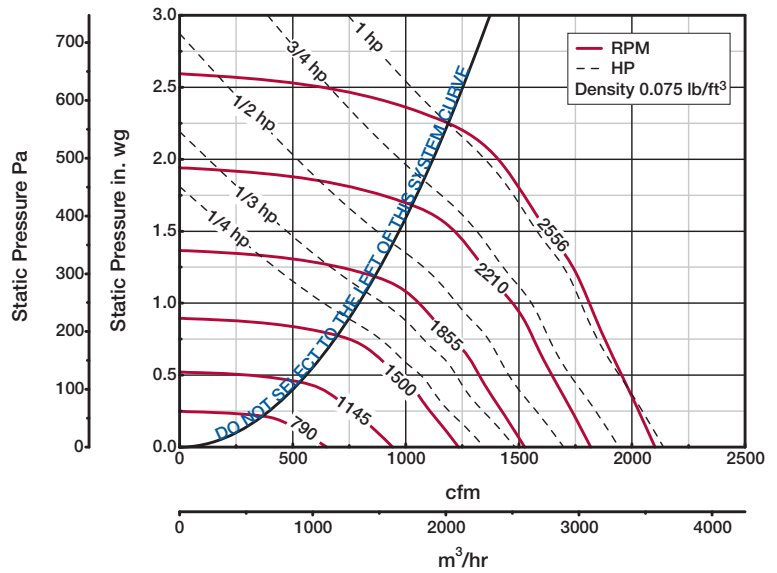
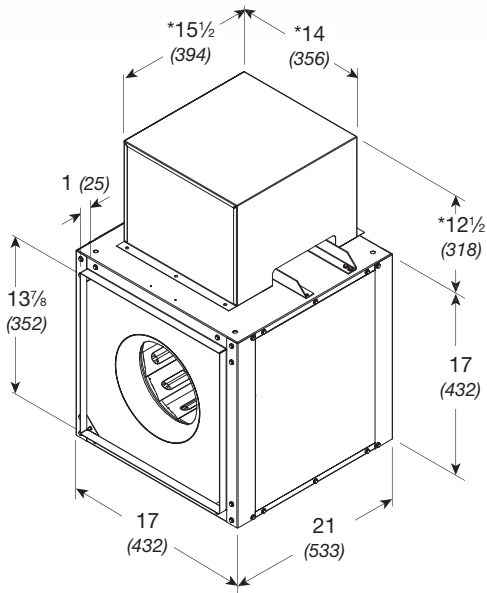

Damper size = 14 x 14 (357 x 357)
 Unit weight** = 91 (41)
 Housing thickness = 18 ga

Dimensions shown in inches (millimeters) and weight is shown in pounds (kilograms).
 *Motor cover is optional. Size may be greater depending on motor.
 **Weight shown is largest cataloged Open Drip Proof motor.

Model Number	Motor HP	Fan RPM	CFM / Static Pressure in Inches wg										
			0.125	0.250	0.500	0.625	0.750	1.000	1.250	1.500	1.750	2.000	
100													
100-4	1/4	1050	CFM	774	671								
			BHP	0.072	0.073								
			Sones	7.9	7.6								
		1330	CFM	1024	953	770							
			BHP	0.14	0.15	0.15							
			Sones	11.3	10.6	9.4							
		1469	CFM	1145	1080	931	837						
			BHP	0.19	0.20	0.20	0.20						
			Sones	13.2	12.6	11.0	10.5						
		1609	CFM	1265	1207	1088	1003	917					
			BHP	0.25	0.25	0.26	0.26	0.26					
			Sones	15.4	15.0	13.4	12.4	11.8					
100-3	1/3	1772	CFM	1405	1352	1247	1187	1110	939				
			BHP	0.33	0.34	0.35	0.35	0.35	0.35				
			Sones	16.6	16.4	15.5	14.8	14.3	13.1				
100-5	1/2	1901	CFM	1515	1465	1366	1320	1255	1115				
			BHP	0.40	0.41	0.43	0.43	0.43	0.43				
			Sones	18.0	17.8	17.4	17.1	16.6	16.2				
		2029	CFM	1623	1577	1484	1439	1396	1262	1119			
			BHP	0.49	0.50	0.52	0.52	0.52	0.52	0.52			
			Sones	19.8	19.6	19.4	19.0	18.6	18.2	17.2			
100-7	3/4	2176	CFM	1747	1704	1617	1574	1533	1428	1305	1163		
			BHP	0.60	0.61	0.63	0.64	0.65	0.65	0.65	0.65		
			Sones	21	21	21	21	20	19.8	19.3	18.5		
		2323	CFM	1871	1830	1749	1708	1668	1591	1472	1358	1197	
			BHP	0.73	0.74	0.76	0.78	0.79	0.79	0.79	0.79	0.78	
			Sones	23	23	23	23	23	22	21	20	21	
100-10	1	2440	CFM	1969	1930	1853	1815	1776	1703	1605	1494	1377	1184
			BHP	0.84	0.86	0.88	0.89	0.90	0.91	0.91	0.91	0.91	0.88
			Sones	25	25	24	24	25	23	23	22	22	23
		2556	CFM	2066	2029	1956	1919	1882	1810	1734	1626	1522	1402
			BHP	0.97	0.98	1.01	1.02	1.03	1.05	1.05	1.05	1.05	1.05
			Sones	26	26	25	26	26	25	25	24	22	24

MAX Bhp AT A GIVEN RPM = (rpm/2517)³
 MAXIMUM RPM = 2556
 TIP SPEED (ft/min) = rpm x 2.928
 MAX NEMA MOTOR FRAME SIZE = 145T
 OUTLET VELOCITY (ft/min) = 0.7617 x cfm

Performance certified is for installation type B: Free inlet, Ducted outlet. Power rating (Bhp) does not include transmission losses. Performance ratings do not include the effects of appurtenances (accessories).
 The sound ratings shown are loudness values in fan sones at 1.5 m (5 feet) in a hemispherical free field calculated per AMCA International Standard 301. Values shown are for installation type B: free inlet hemispherical sone levels.