

FIELD INSTALLATION INSTRUCTIONS *for*

Extension Pin Kit & Manual Quadrant Operators on (VCD) Control Dampers



Kit Part Numbers

1/2" Extension Pin Kit	Part #809735
1/2" Manual Quadrant Kit	Part #811518
1/2" Extension Pin Kit & Manual Quadrant Kit	Part #815607
1" Manual Quadrant Kit	Part #813938

TOOLS REQUIRED:
 5/16" Hex Nut Driver
 3/8" Electric Drill
 1/2" Open End Wrench

**NOTE: FOR DAMPERS
INSTALLED IN DUCTS**
 Extended Control Shaft is
 installed from outside of duct
 after damper is installed.
 Install as shown below.

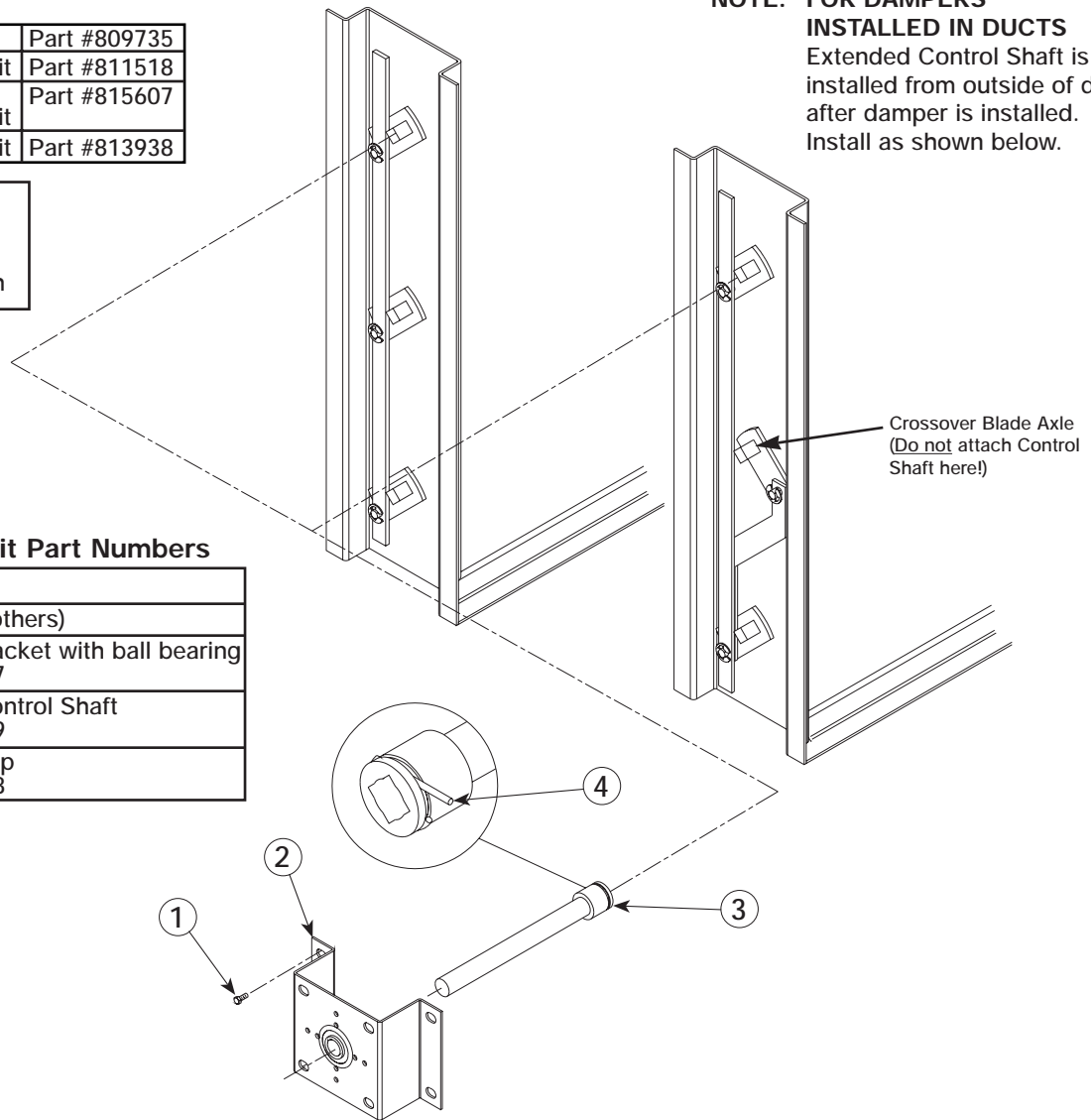

1/2" Extension Pin Kit Part Numbers

No.	Qty.	Description
1	4	Screws (by others)
2	1	Stand off bracket with ball bearing Part #815027
3	1	Extended Control Shaft Part #452509
4	1	Retaining Clip Part #451738

Before Installing Damper in the Duct

1. If damper has more than one blade, determine which blade axle will be driven by the extended control shaft. Always attach extended control shaft to a blade axle which is directly connected to the main linkage tiebar. **DO NOT** attach extended control shaft to a crossover blade axle.
2. Cut hole approximately 1" in diameter in duct where damper drive blade axle will be located. Hole must provide clearance for enlarged portion of extended control shaft.

Standard Control Shaft location is the third blade from the bottom on dampers with three or more blades. Control Shaft location is the first blade from the bottom on dampers with one or two blades.

2. Install the stand off bracket with bearing over the extended control shaft and screw bracket to duct. Make sure screws (provided by others) do not interfere with damper linkage or blade movement.

After Damper Is Installed in Duct

1. Push extended control shaft through hole in duct and onto drive blade axle. Retainer clip should "click" into groove on drive blade axle and hold shaft into place.

Caution

Stand off bracket with bearing is needed to support the extended control shaft. If not installed as directed, the extended control shaft may not operate the damper correctly.

CONTINUED INSTALLATION INSTRUCTIONS *for* Manual Quadrant Operator

Manual Quadrant & Extension Pin Kit Part Numbers

No.	Qty.	Description	Part Number
1	1	Extension Pin Kit Assembly	See Page 1
2	2	#10 x 1/2" Self Drilling SMS	415555
3	1	1/2" Dia. Manual Quadrant	455648
4	1	OPEN & CLOSED Labels	452690
5	1	Washer (included with Part #455648)	

* The 1/2" manual quadrant kit (Part #811518) does not include Item #1 above. Kit part #815607 includes both the 1/2" manual quadrant kit and the 1/2" extension pin kit.

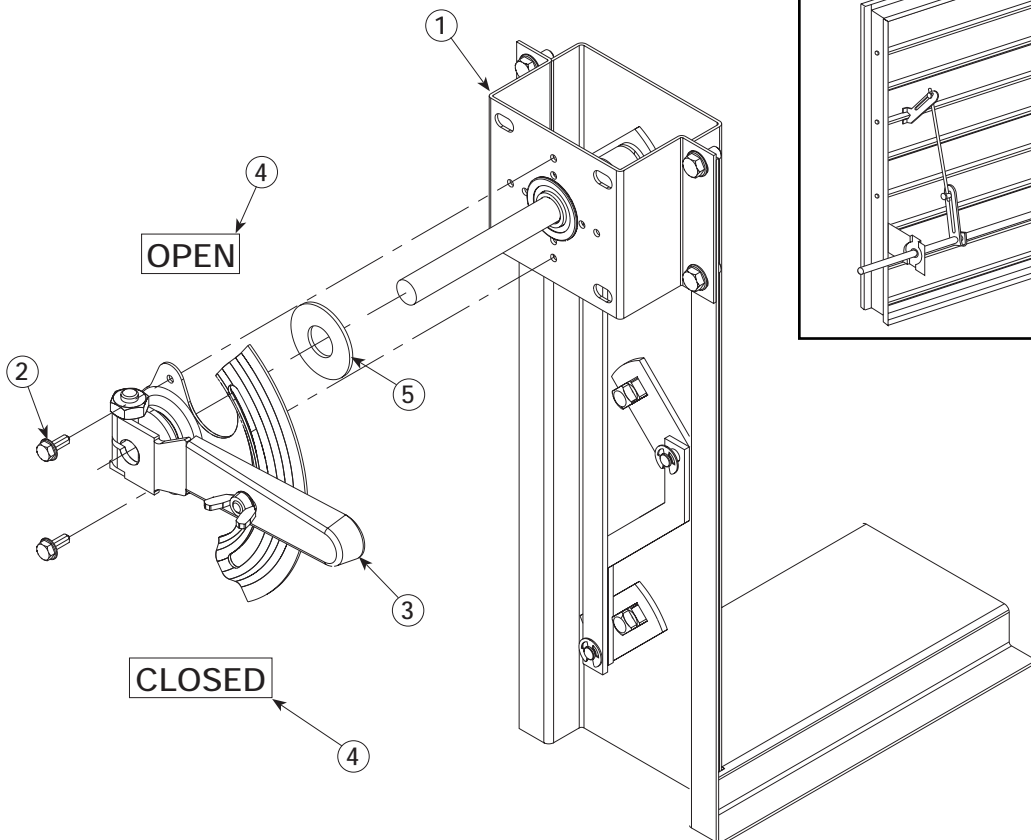

Jackshafted Damper

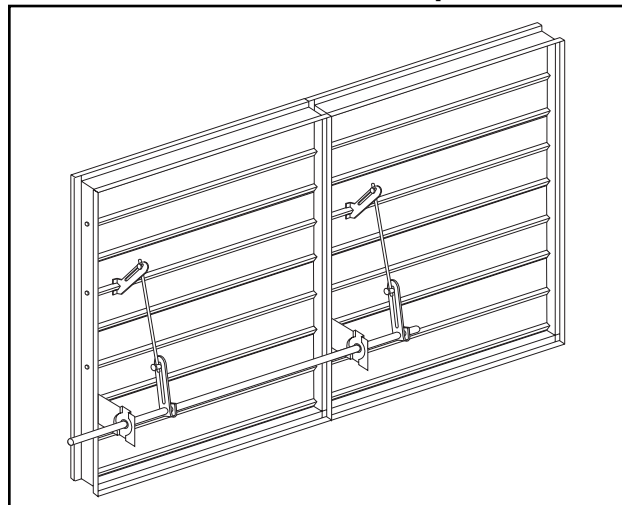

Non-jackshafted Dampers

Control damper should be mounted in the duct and the shaft extension mounted onto the correct blade of the damper before continuing with these instructions.

After Extended Shaft is Installed

1. Assemble Manual Quadrant to extension bracket assembly (screws provided).
2. With damper either fully open or closed, lock manual quadrant to extended control shaft so manual quadrant can move damper between open and closed. Apply "OPEN" and "CLOSED" labels if damper movement is opposite to that engraved in the manual quadrant.
3. Set damper to desired position and tighten wing nut on manual quadrant to hold damper in place.

Jackshafted Dampers

1. Units that are jackshafted do not require Item #1. The jackshaft is, either, 1/2" diameter or 1" diameter depending upon the size of the damper. The manual quadrant kit for the 1/2" diameter jackshaft is Part #811518 and the manual quadrant kit for a 1" diameter jackshaft is Part #813938.
2. With damper either fully open or closed, lock manual quadrant to jackshaft so manual quadrant can move damper between open and closed. Apply "OPEN" and "CLOSED" labels if damper movement is opposite to that engraved in the manual quadrant.
3. Set damper to desired position and tighten wing nut on manual quadrant to hold damper in place.